



# IDEAS

40487



Booklet available in English on  
Heft in deutscher Sprache erhältlich auf  
Livret disponible en français sur  
Libretto disponibile in Italiano su  
Folleto disponible en español en  
如需中文版手册, 请访问

[LEGO.com/service/buildinginstructions](https://LEGO.com/service/buildinginstructions)



# IDEAS



I am a research scientist and engineer but have always been drawn by artistic creativity and aesthetics. I think that is why my passion of toy photography and LEGO® models is such a great match. My passion for building with LEGO bricks, combined with toy photography, makes me feel like an artist telling stories through my models and photos. My entry to the LEGO Ideas competition was also inspired by a story of an adventure that my wife and I still have to experience. We have done a lot of travelling and living abroad, but we have never had the opportunity to go on a sailboat and set sails for the horizon. The sailboat is named “Éloïse” after our daughter, so this is really a celebration of us as a family, which makes it so much more than just a sailboat to me: it’s a dream-come-true, like a perfect holiday. Whenever I look

at my model on my desk, I begin to dream of cruising around exotic destinations, to the sound of the ocean and the dolphins playing around the sailboat. These are the stories that I want to tell with my models, and I am just so happy and honoured that this exact story received so much support from the community. I am so proud of winning the competition, because when you are doing something so important to you, you easily doubt your own skills and ideas. There are so many great builders out there in the community, so it was quite intimidating submitting an entry for the first time. I could not have done this without my wife's support, feedback and inspiration, so without her, I am not sure I would ever have entered the competition. My best piece of advice for any builder of tomorrow, who wants to join a LEGO Ideas competition, is to find a concept and hold on to it. When working with

a creative challenge, too often people start over instead of refining and improving the initial concept they felt inspired by. Show and share your work with friends and family, because you will need their feedback, ideas, knowledge and inspiration, to create something that is truly meaningful and impressive. And when doing something that you are truly proud of, it is also important to have someone to share it with.

*Yan Chevalier, LEGO® Ideas Fan competition Winner,  
Toy Photographer and LEGO Enthusiast*

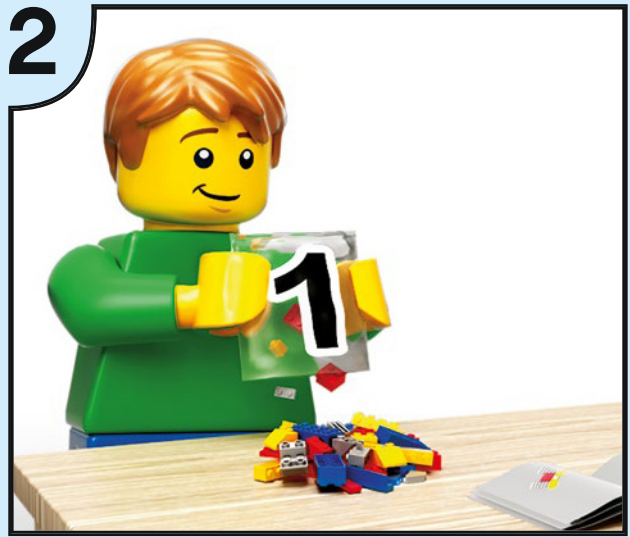

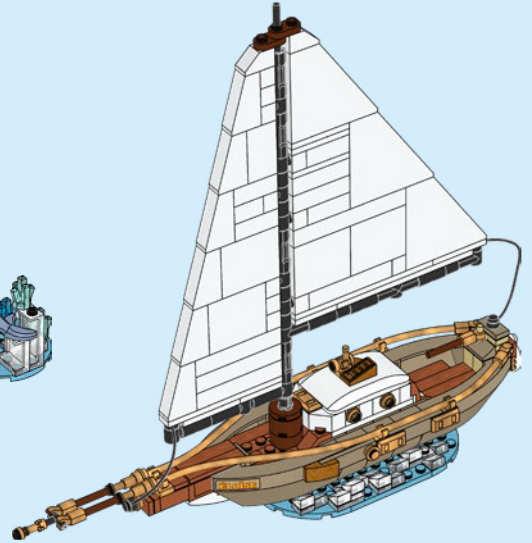
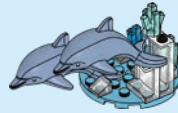
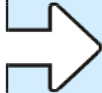
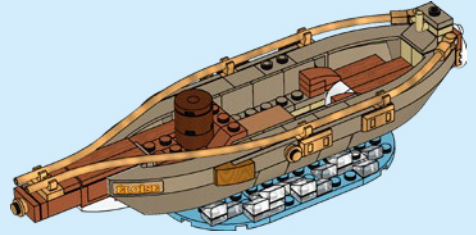
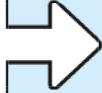



2x

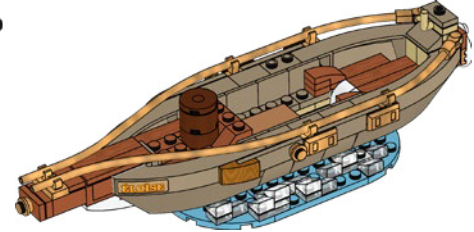
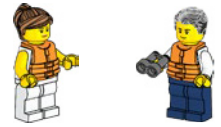
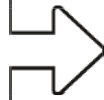

1

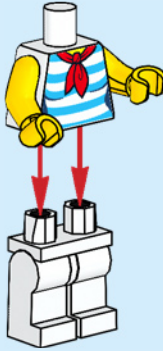

2

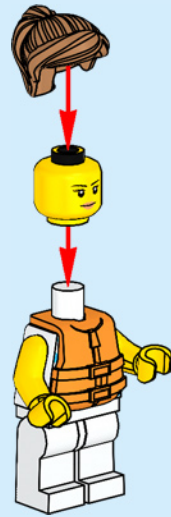

3



1

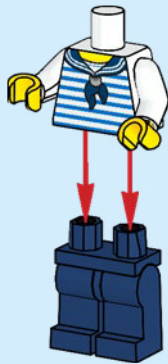

2

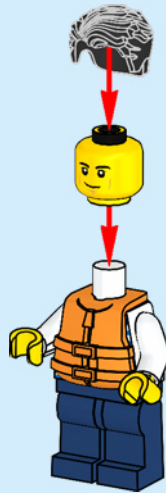

3



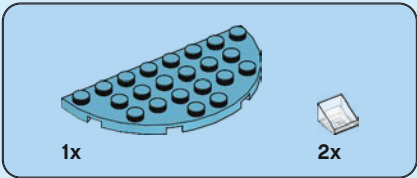

1

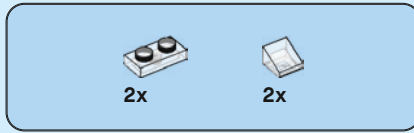
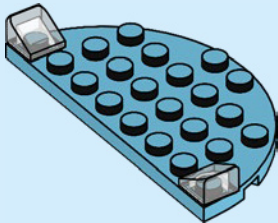

2

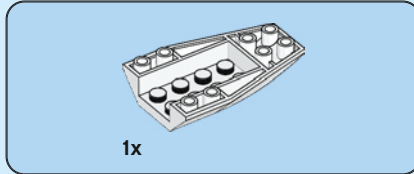
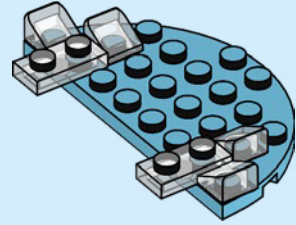

3

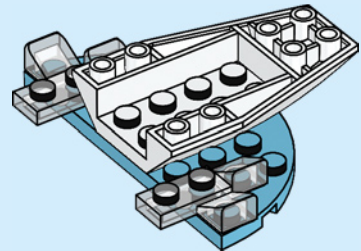



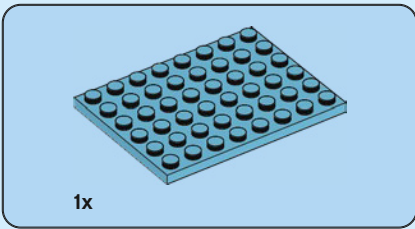

4

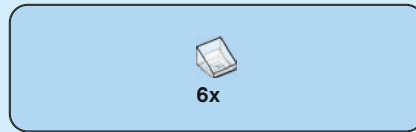
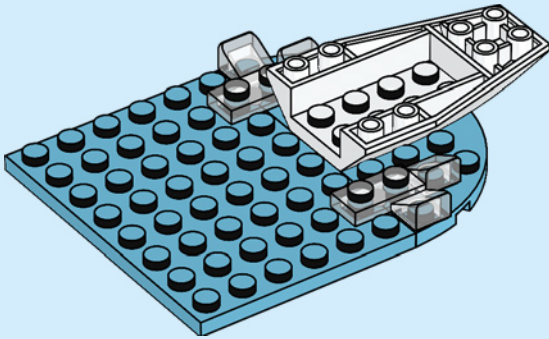

5

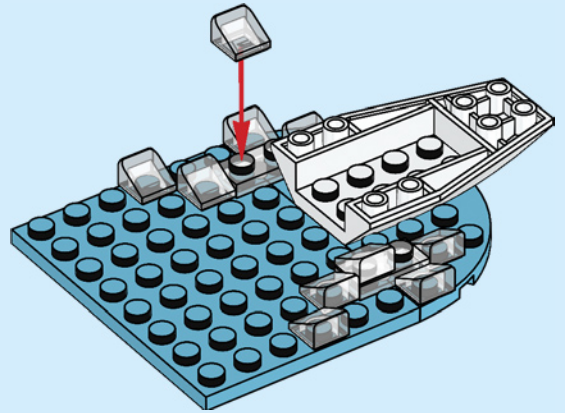

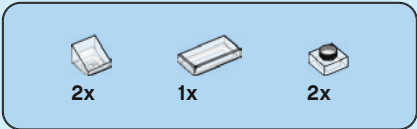

6

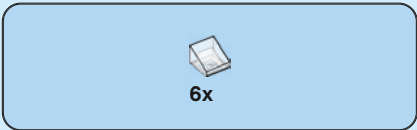
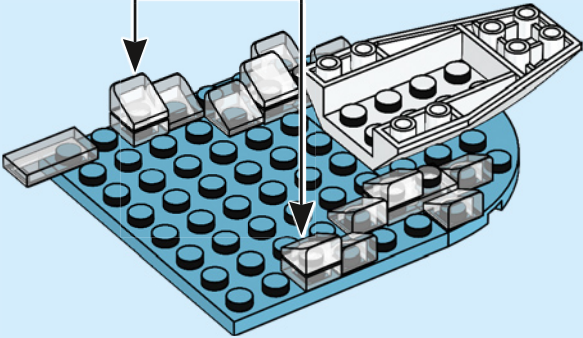
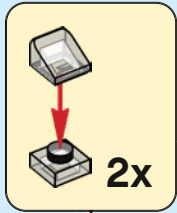

7

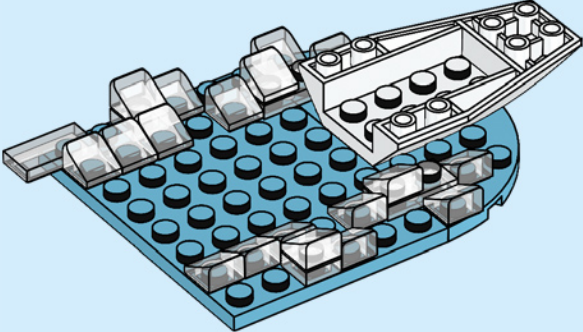

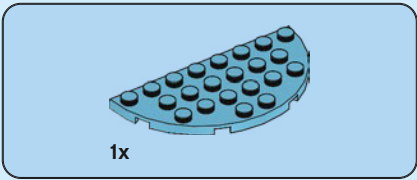

8

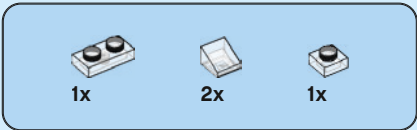
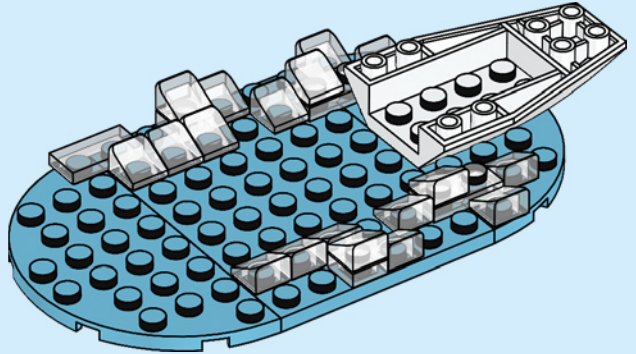

9

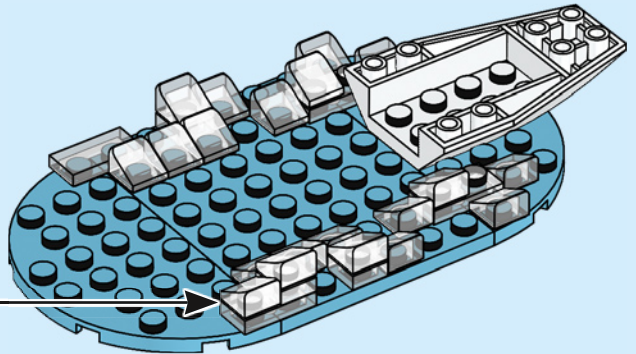
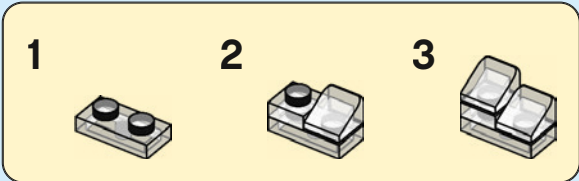



4x



2x

# 10

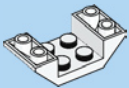
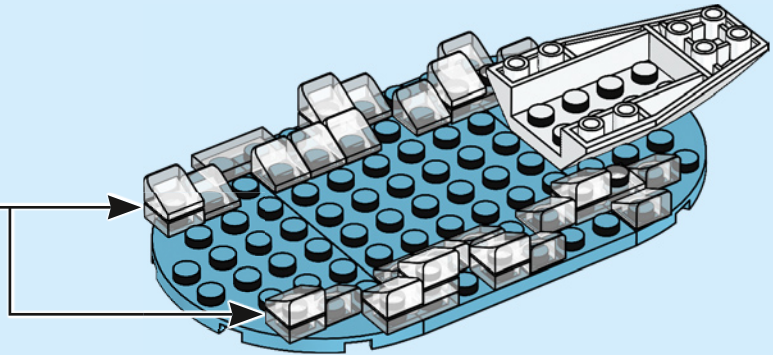
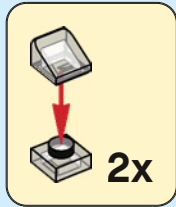

1x



1x

# 11

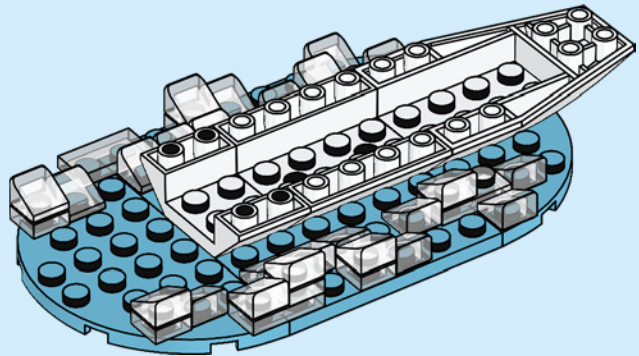

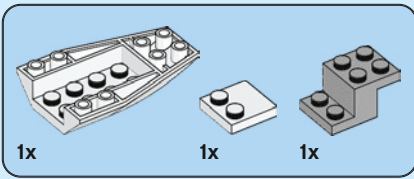

12

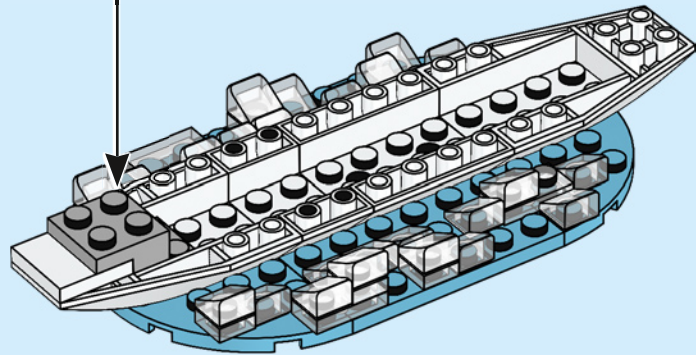
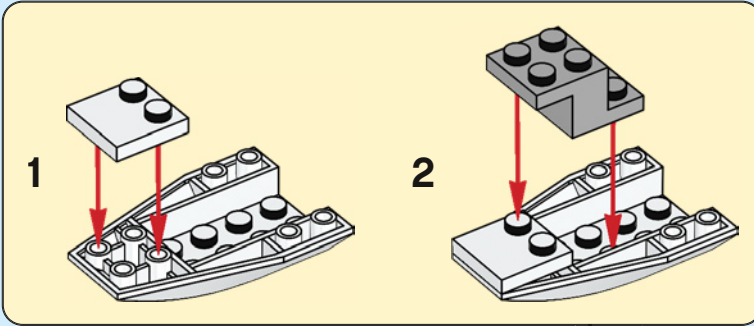

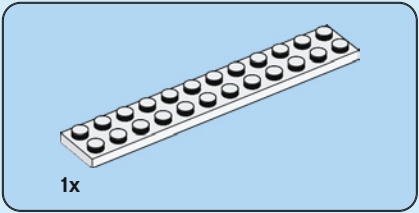

13

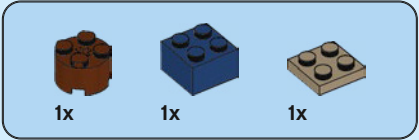
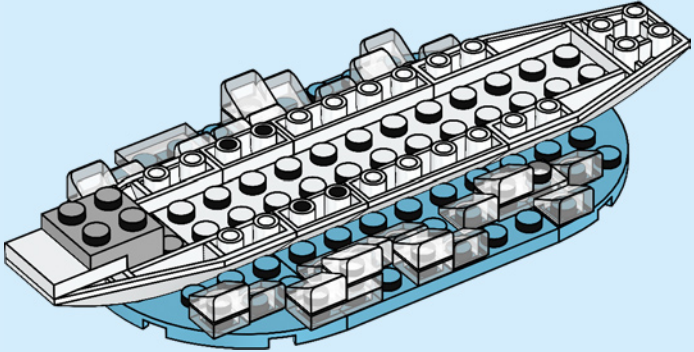

14

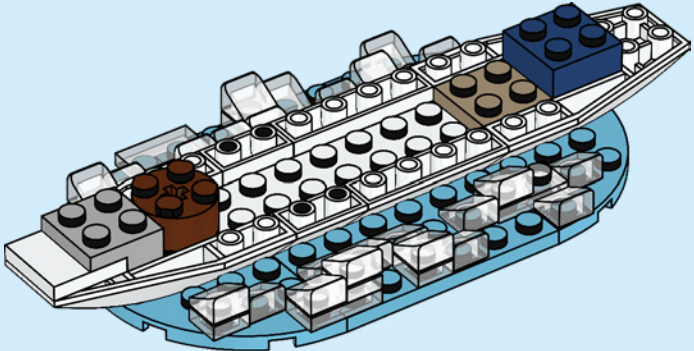

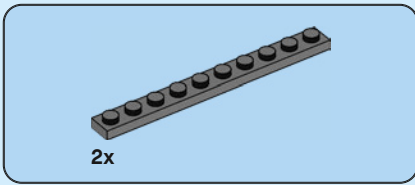

15

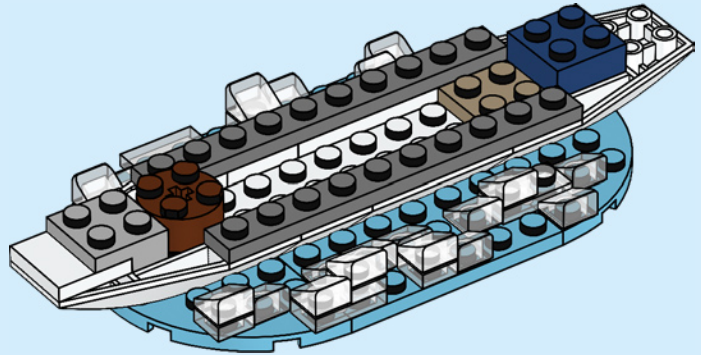

16

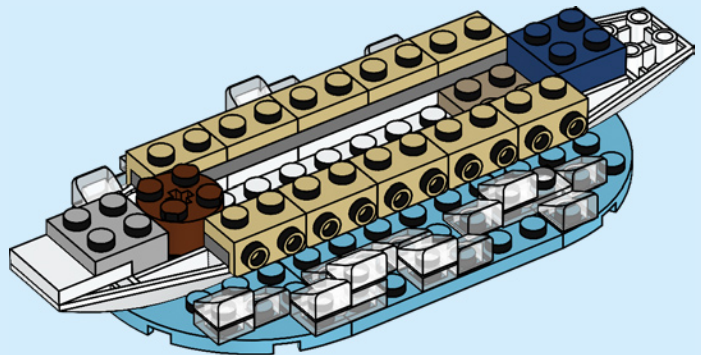

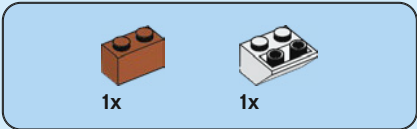

17

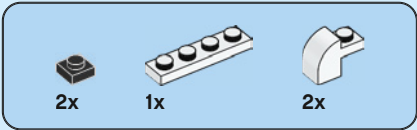
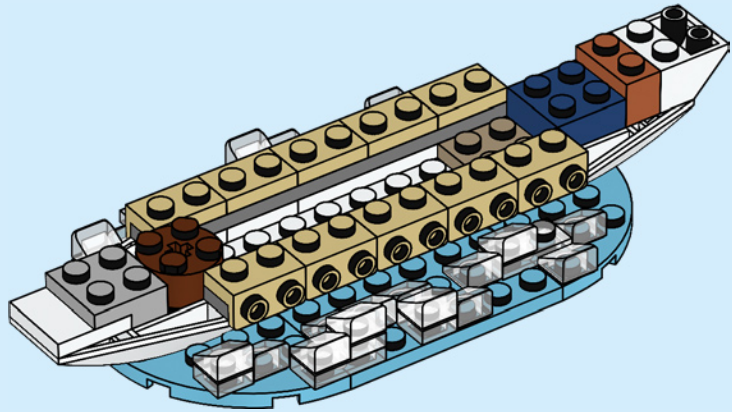

18

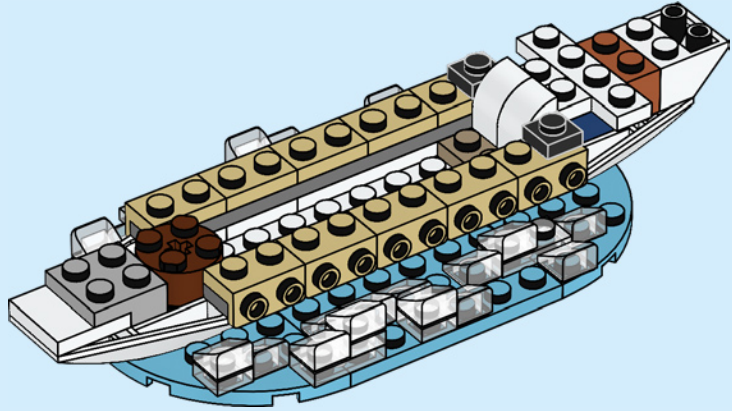



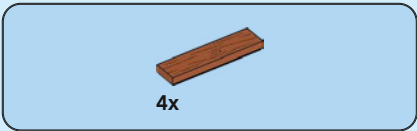

19

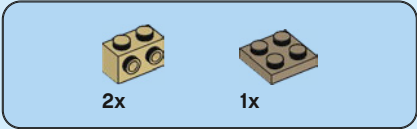
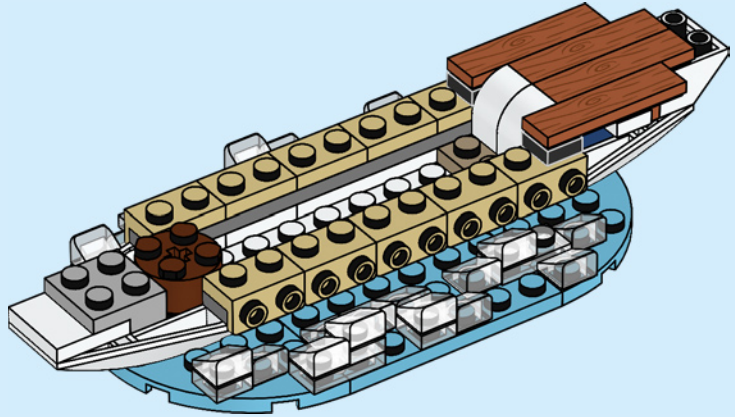

20

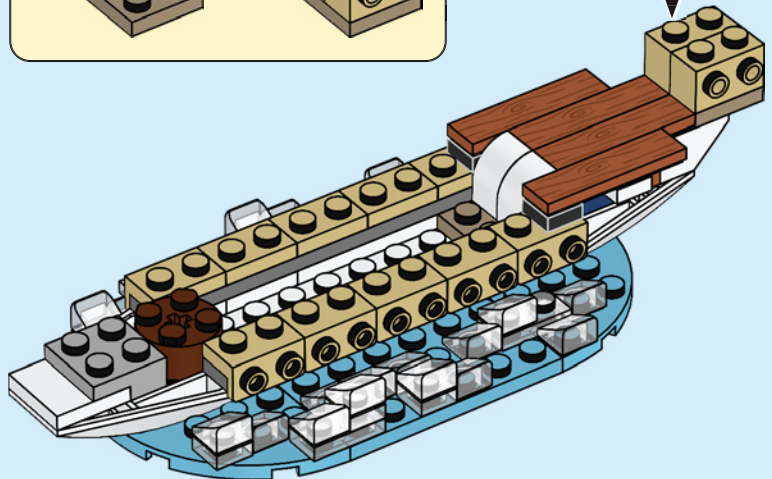
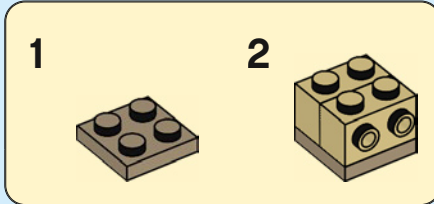



2x

21

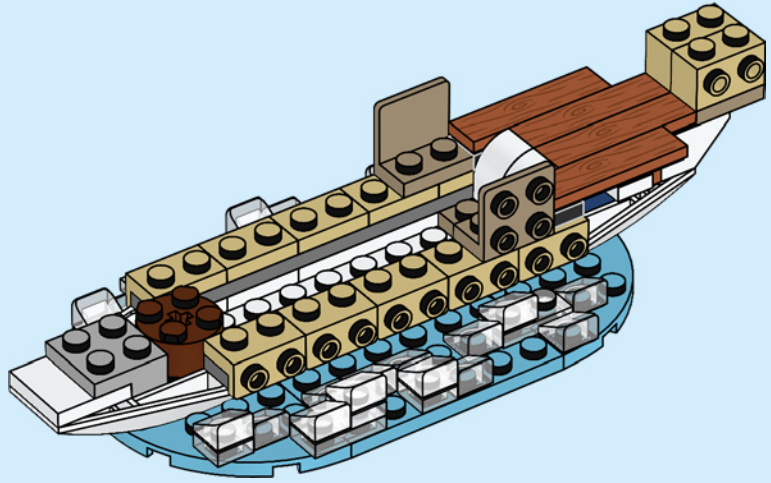

2x



4x

22

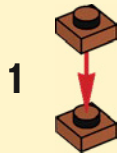

1

2



2x

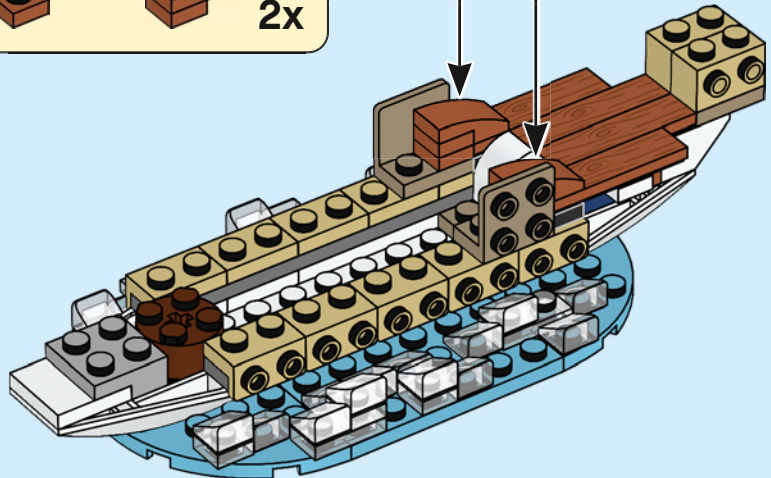



4x

23

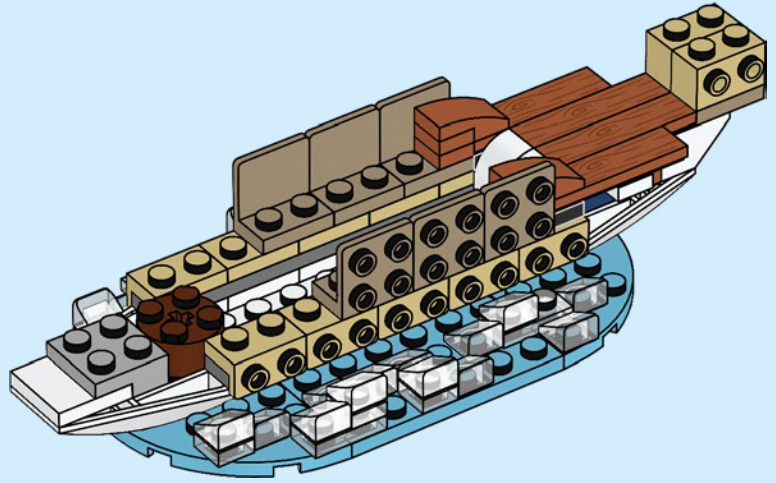

1x



1x

24

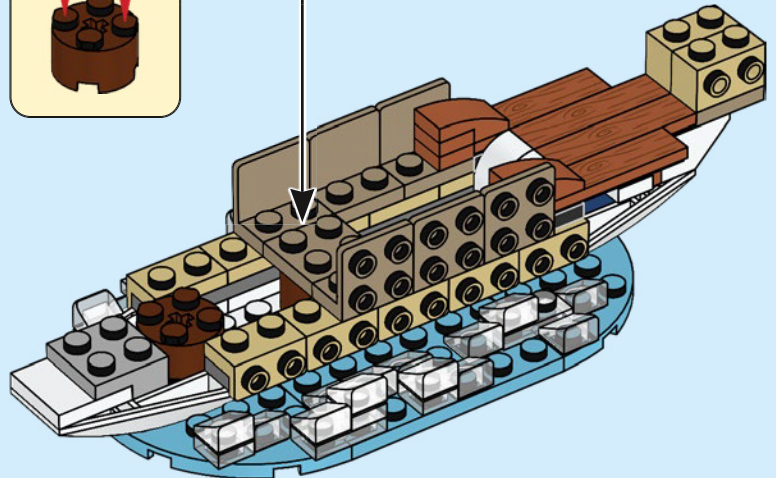
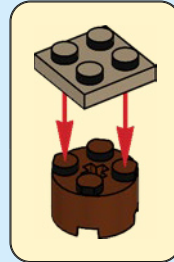



2x

# 25

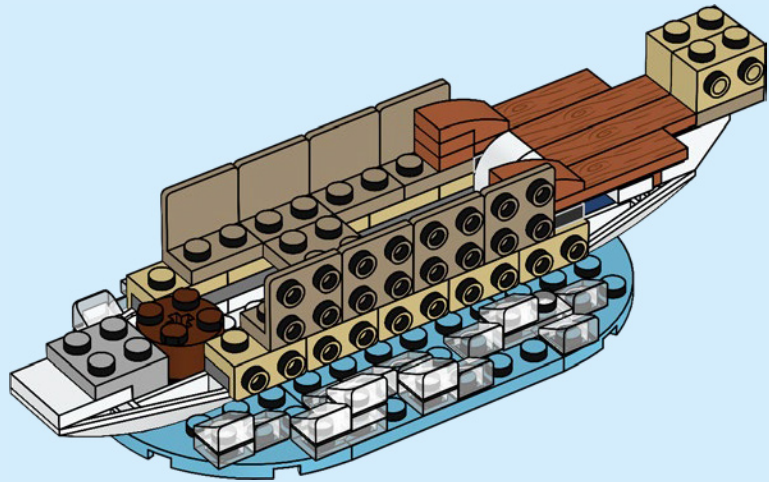

1x



1x

# 26

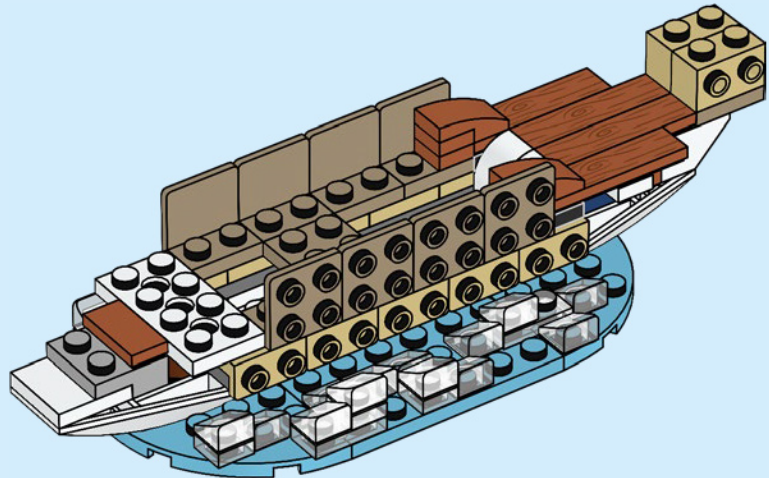

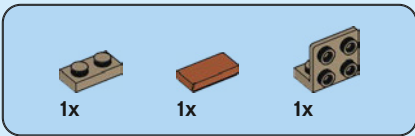

# 27

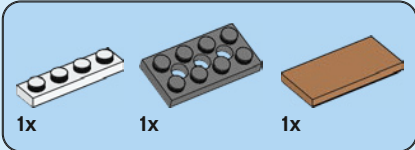
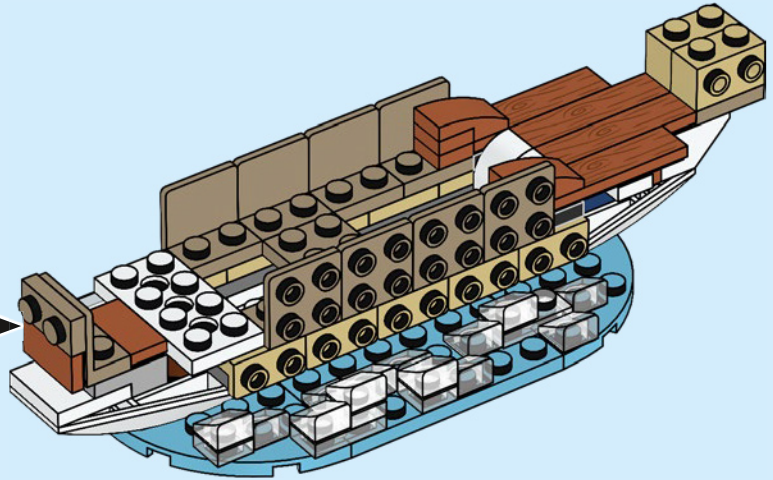
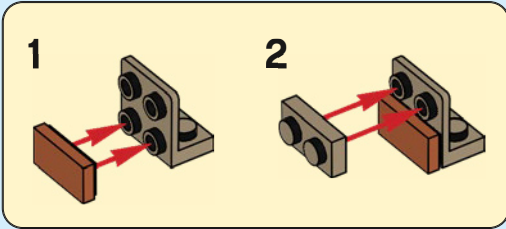

# 28

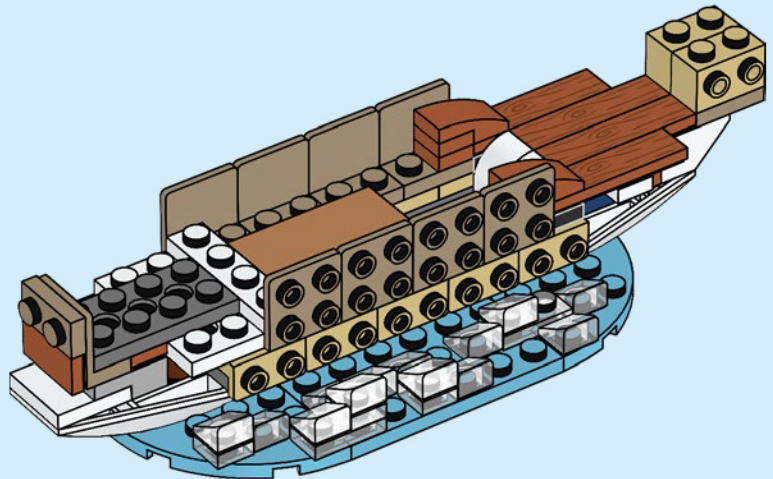

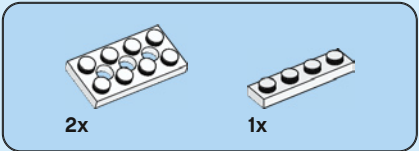

29

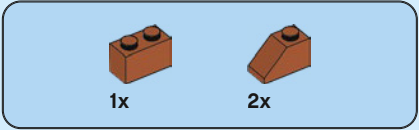
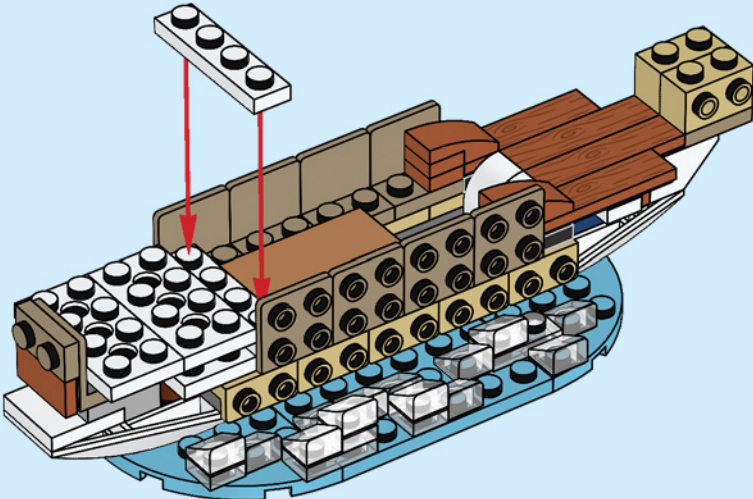

30

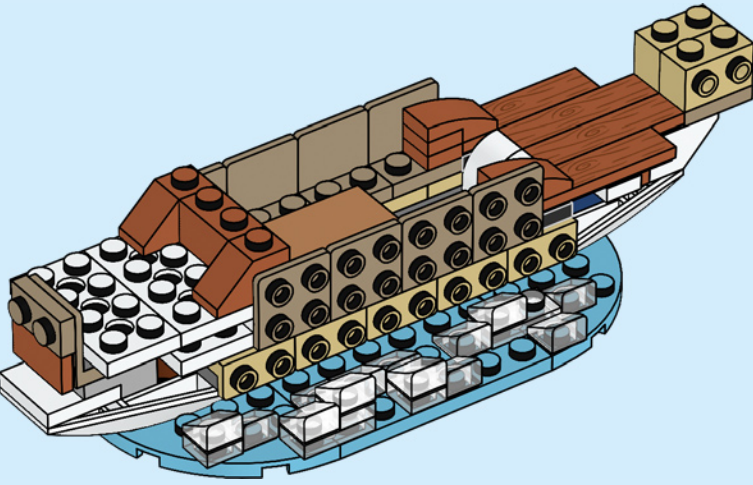



1x



2x

31

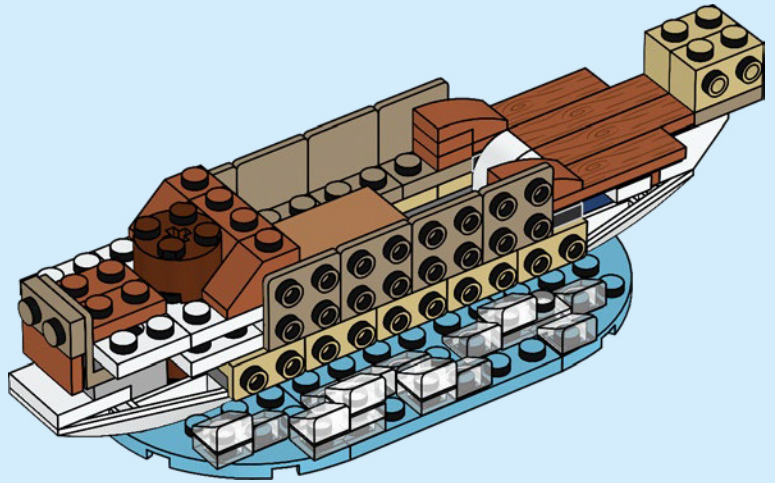

2x

32

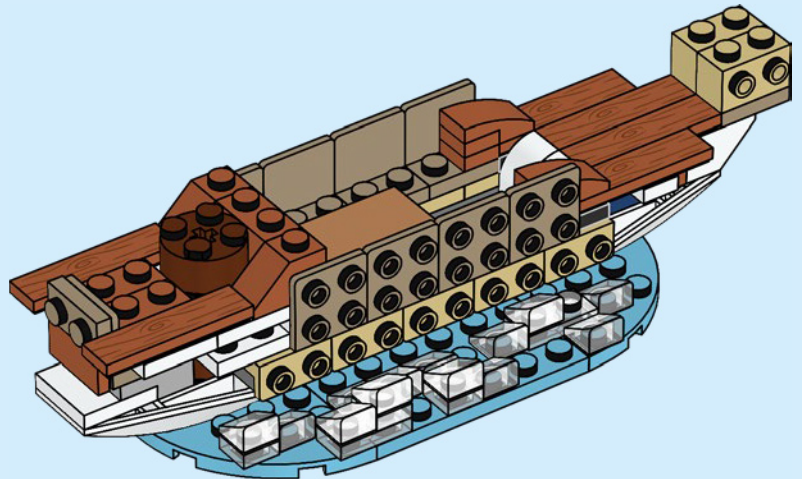

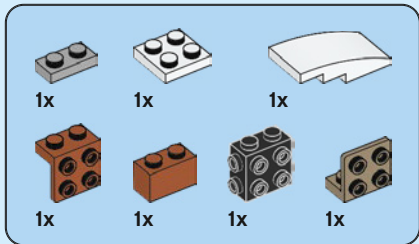

33

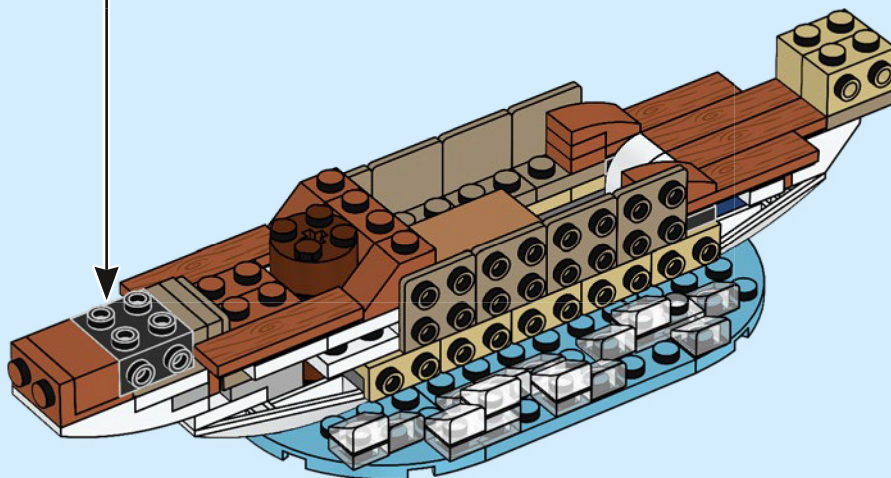
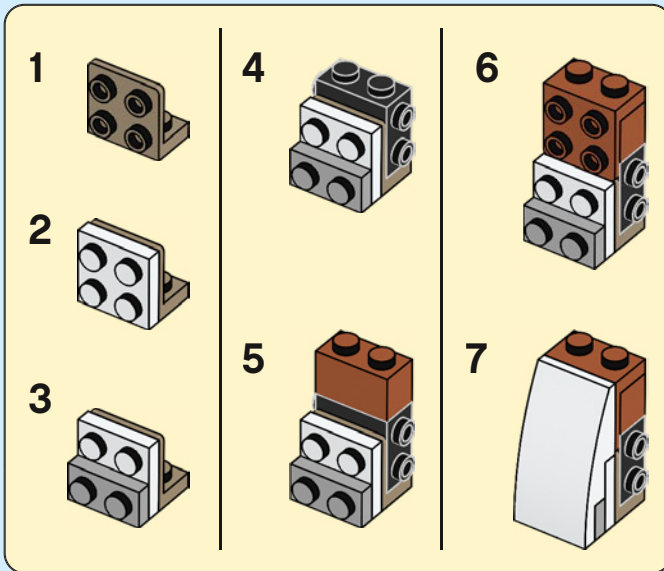



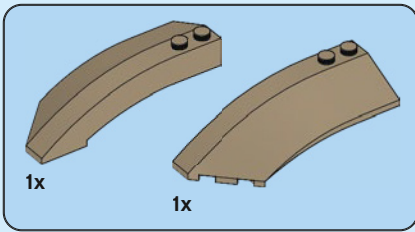

34

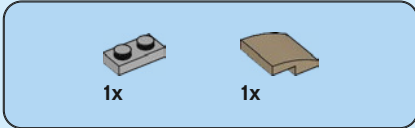
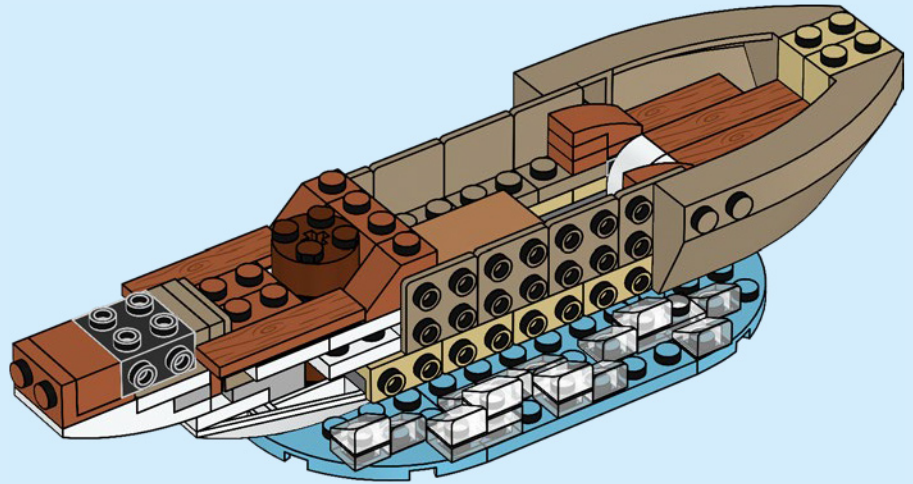

35

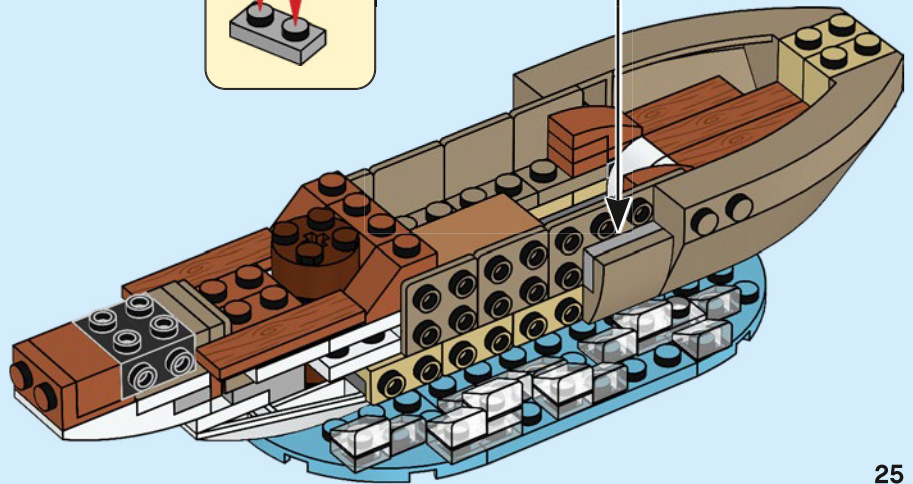
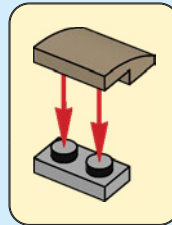

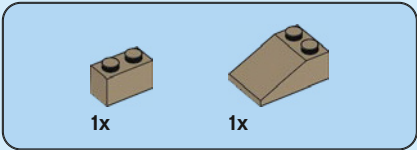

36

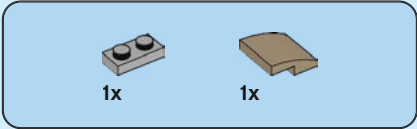
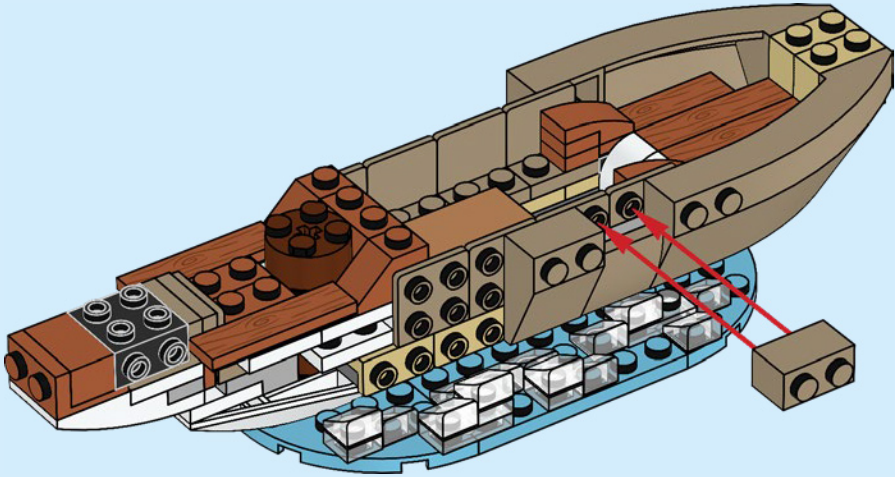

37

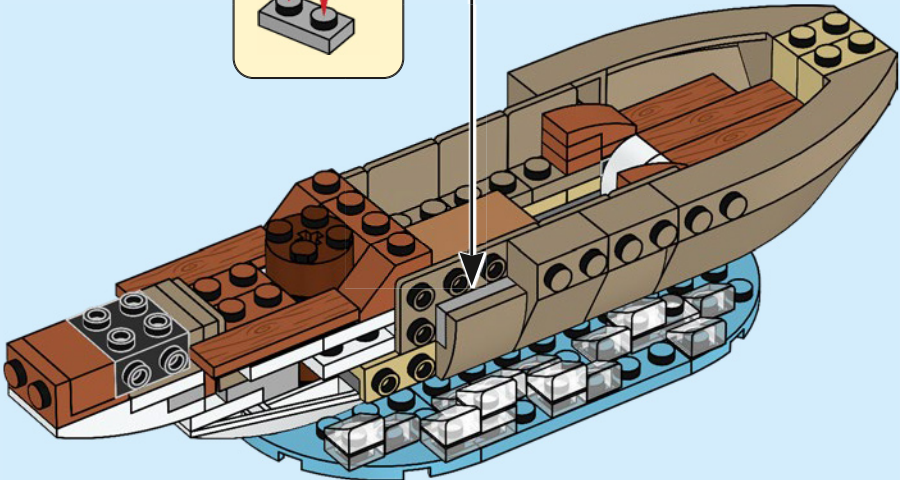
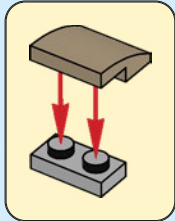

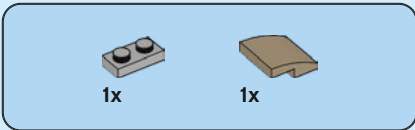

38

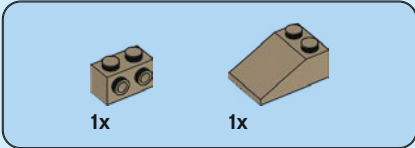
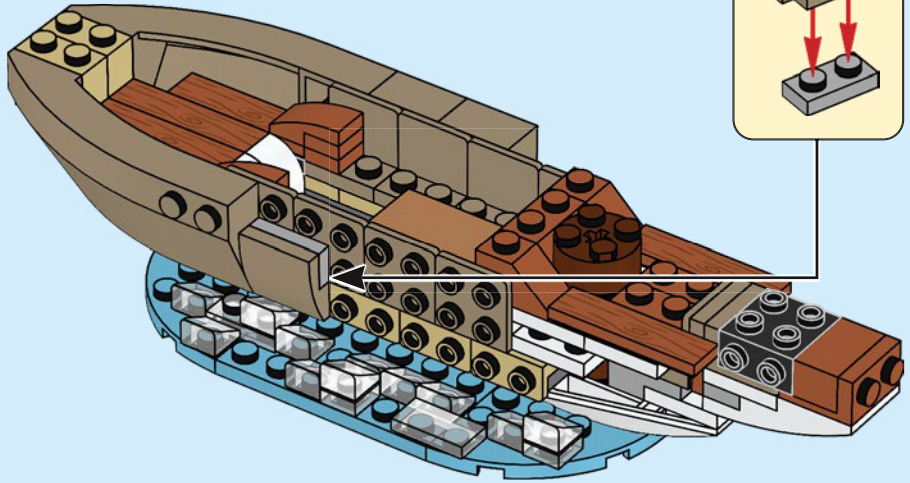
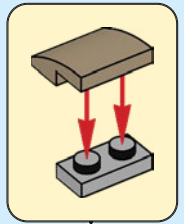

39

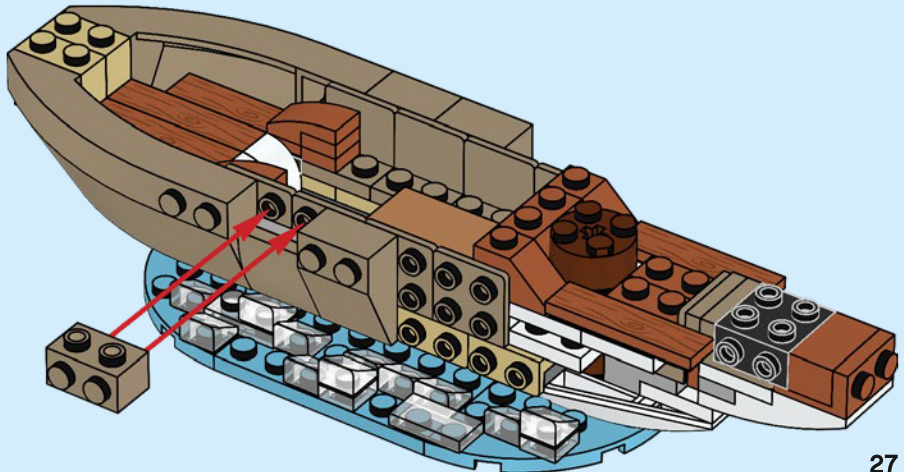



40

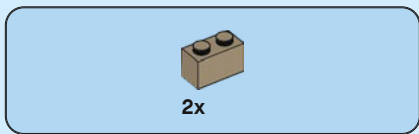
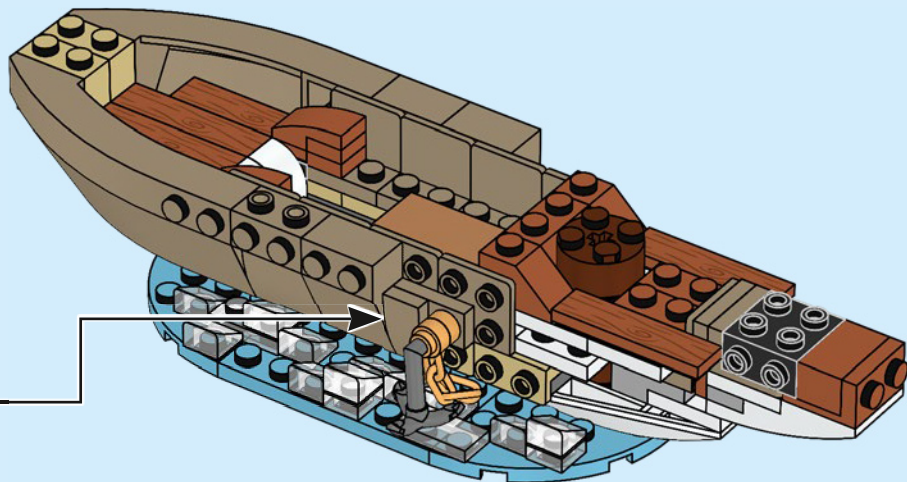
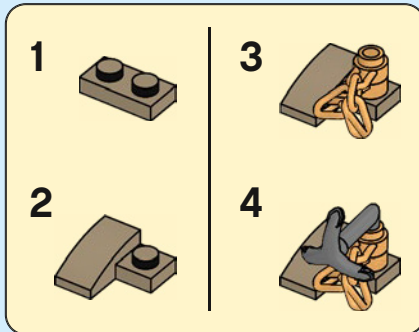

41

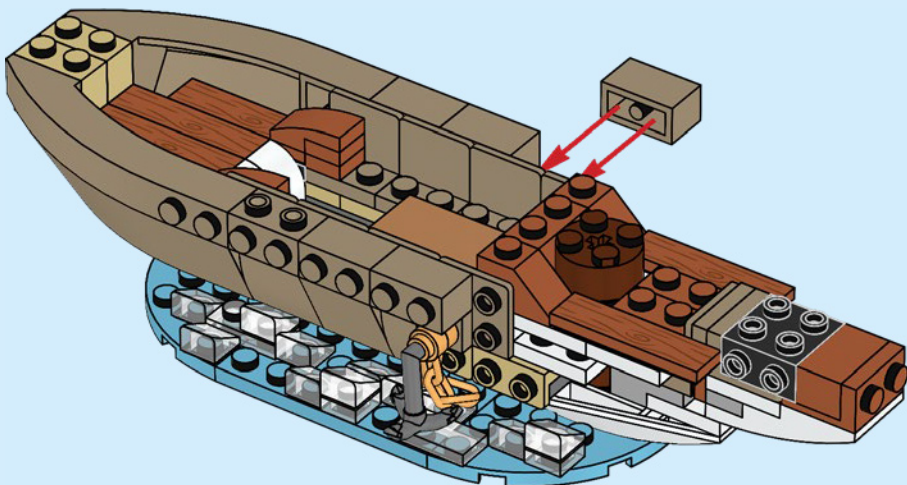

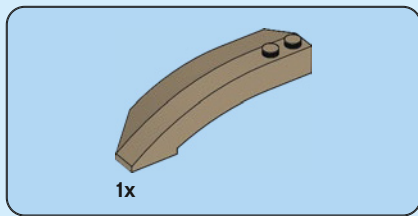

42

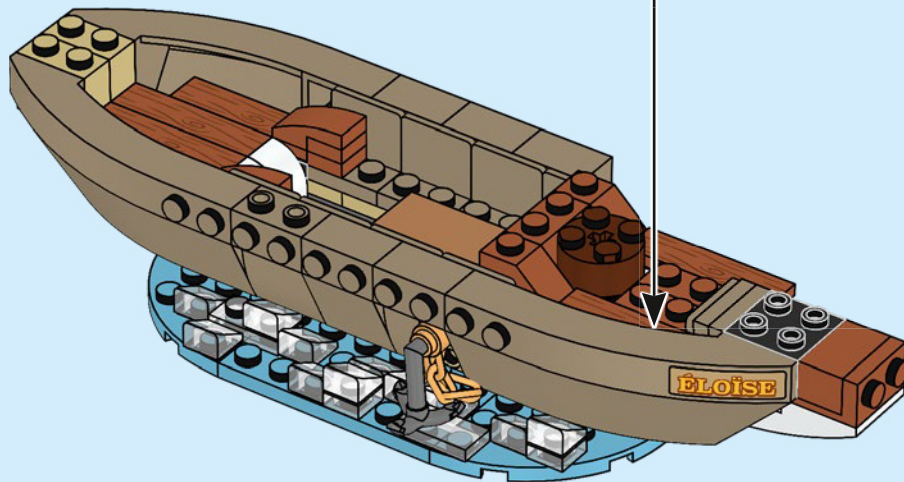
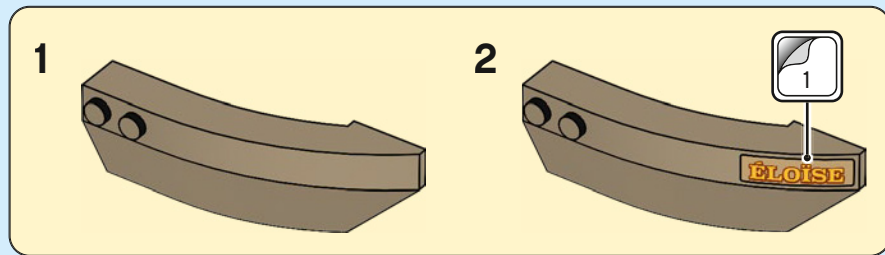

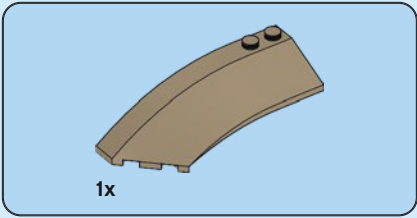

43

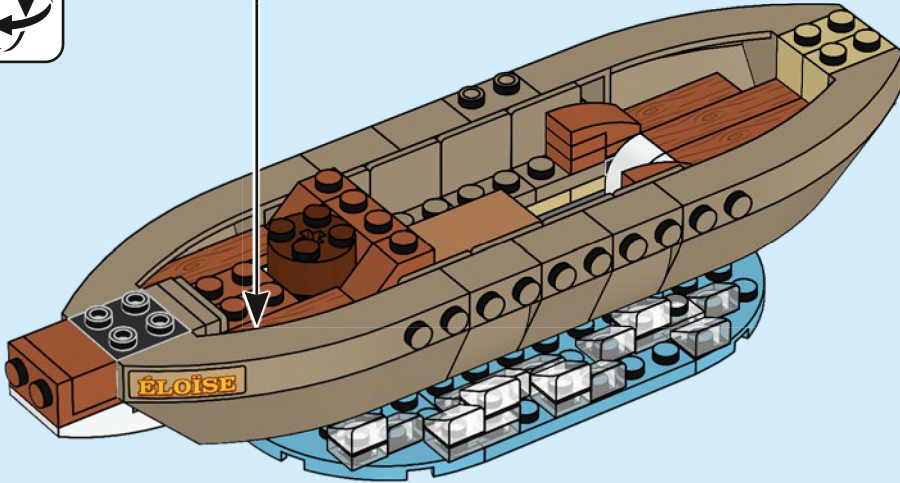
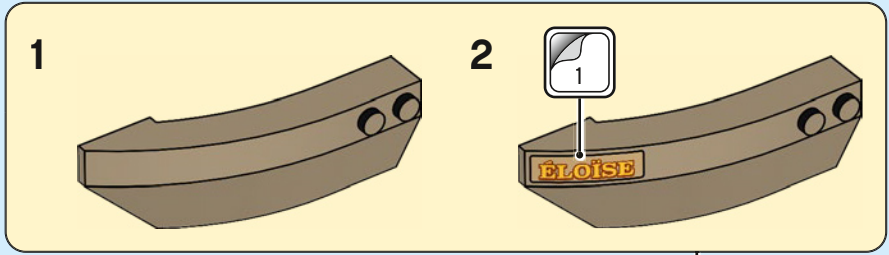

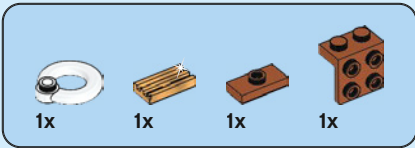

44

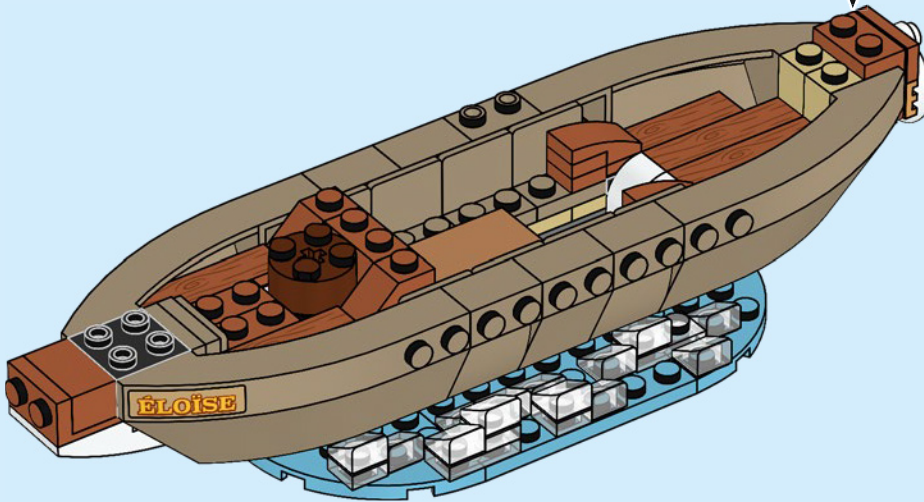
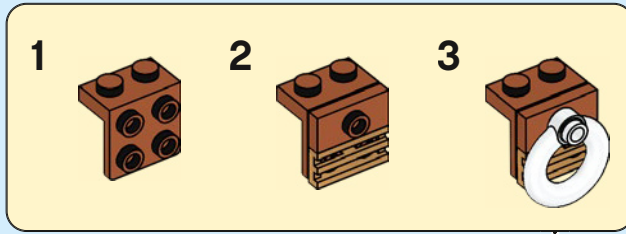



45

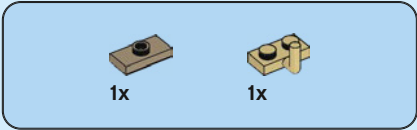
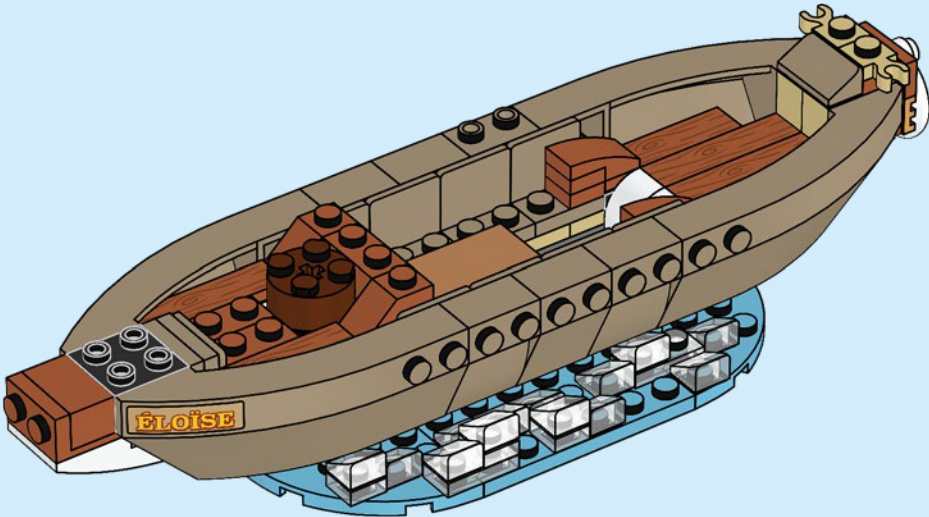

46

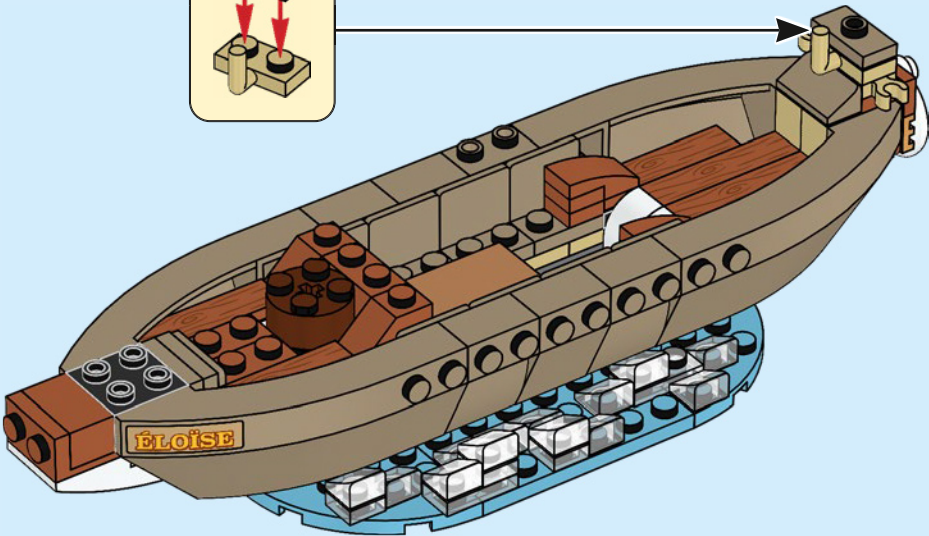
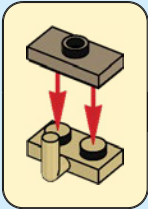



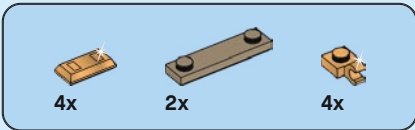

# 47

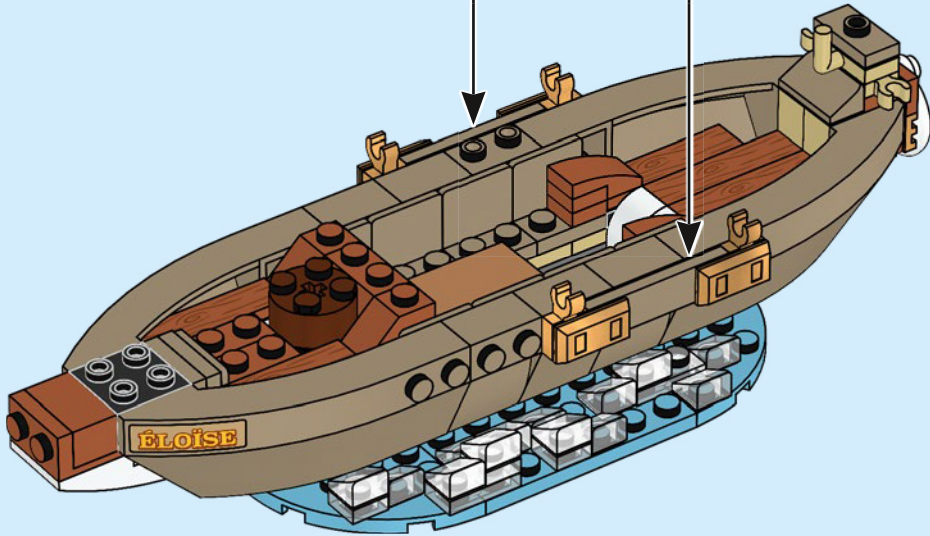
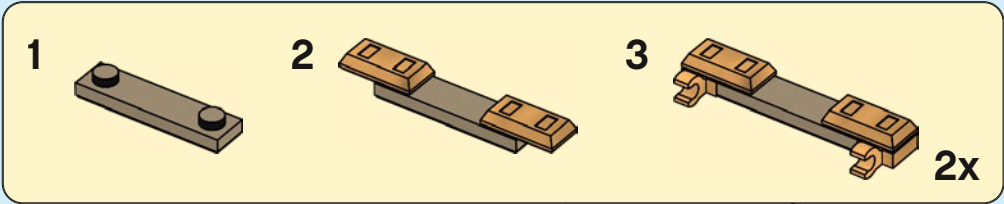

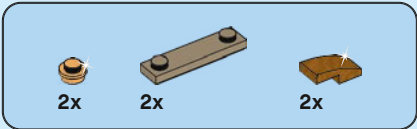

48

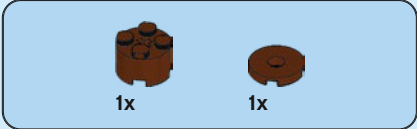
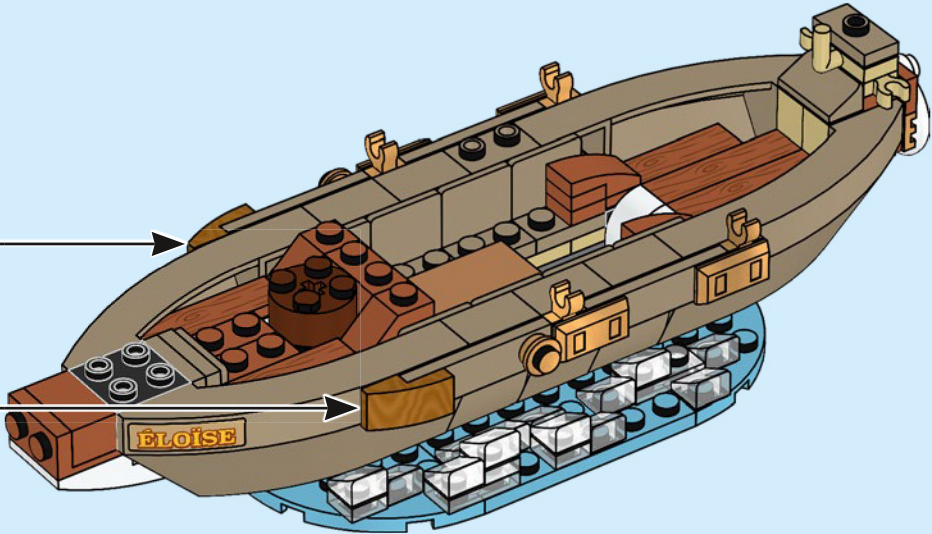
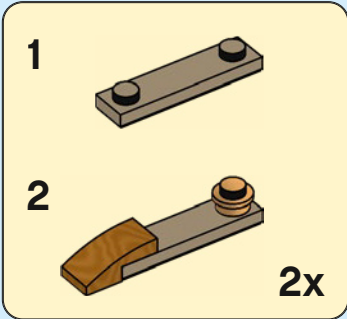

49

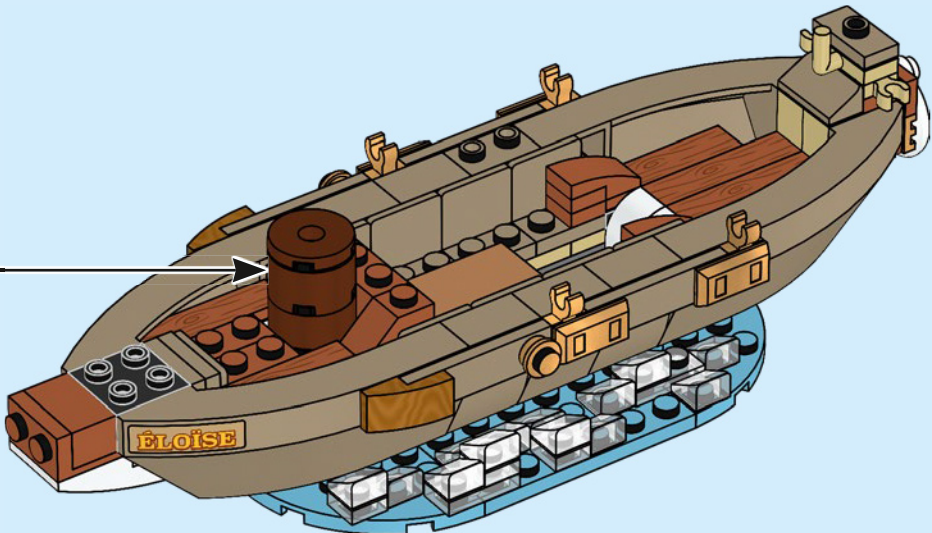
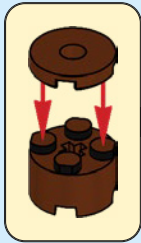

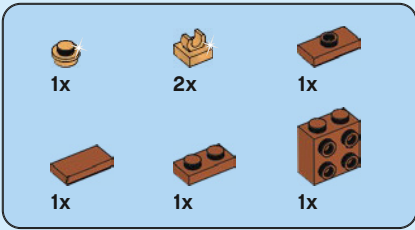

# 50

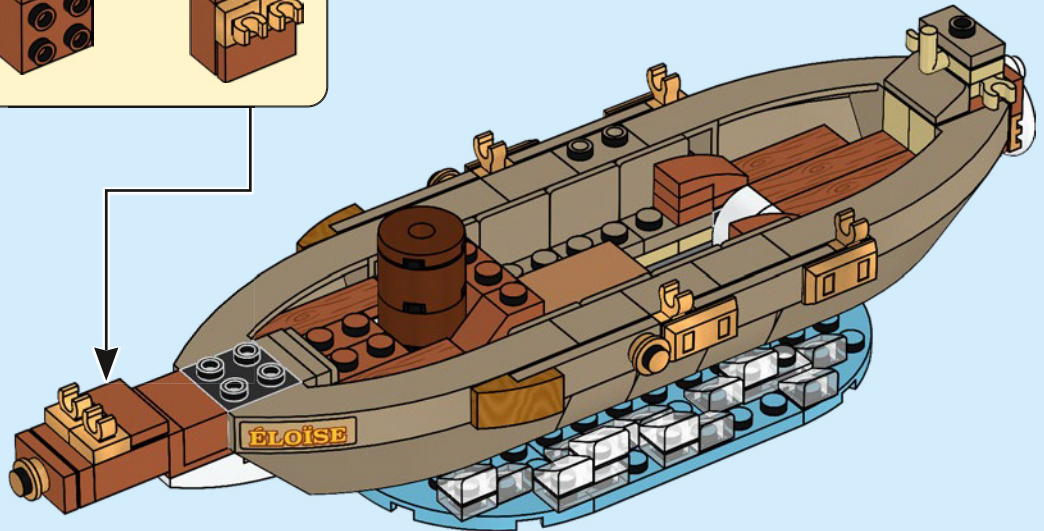
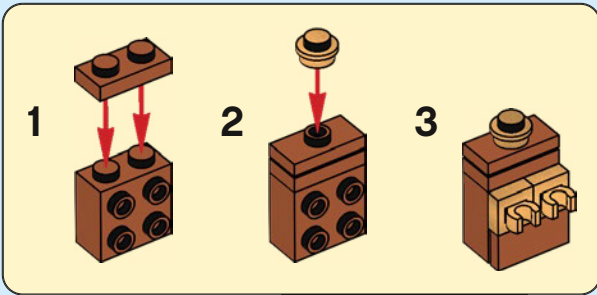



2x

51

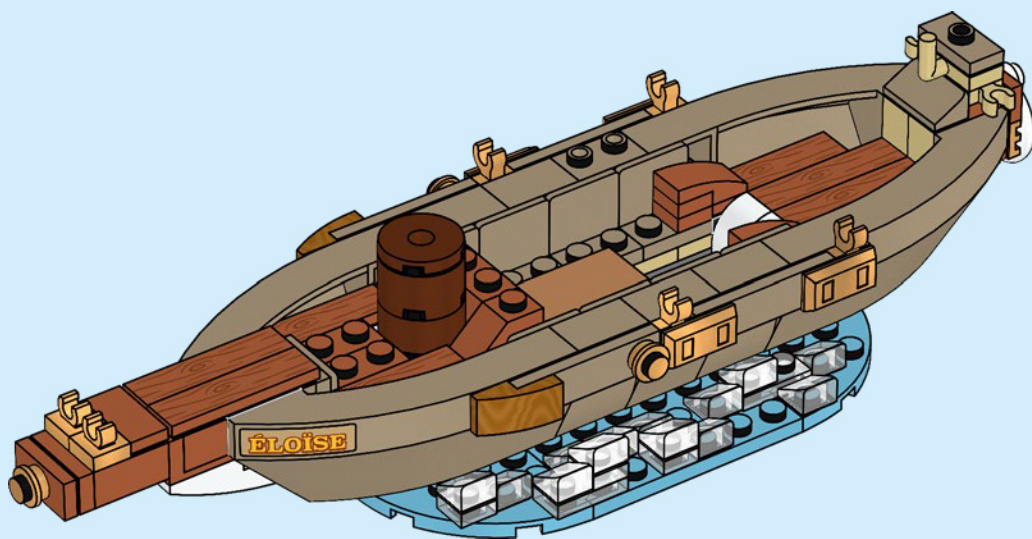

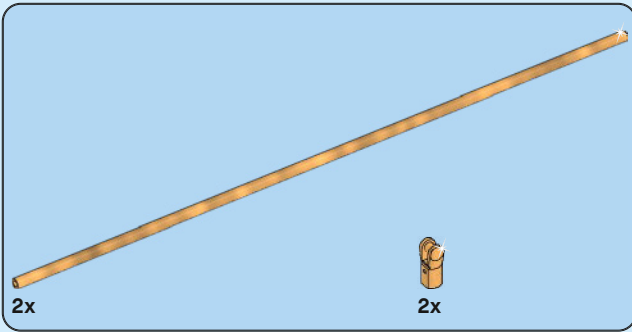

52

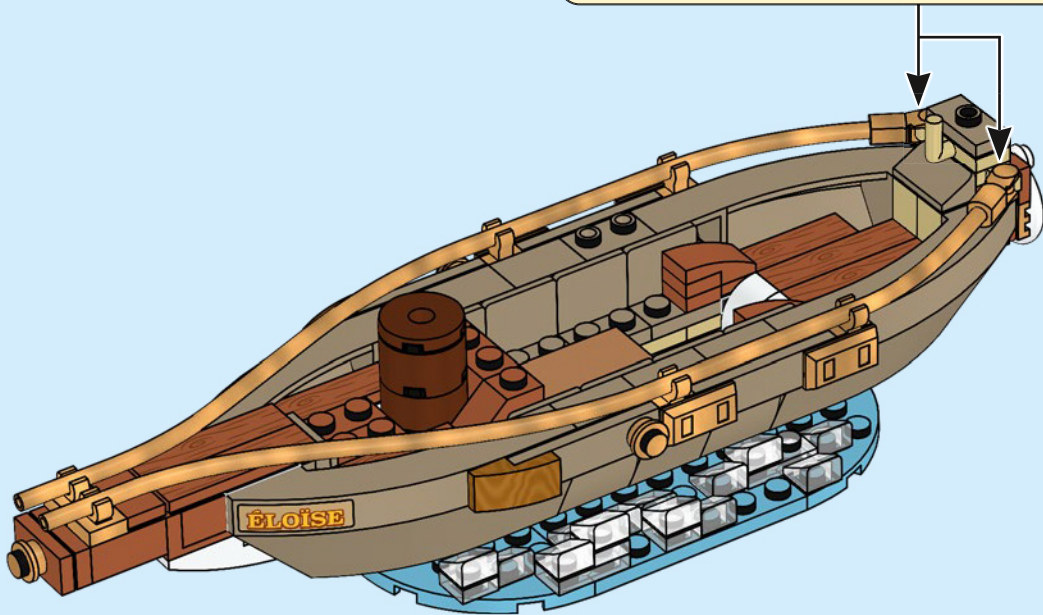
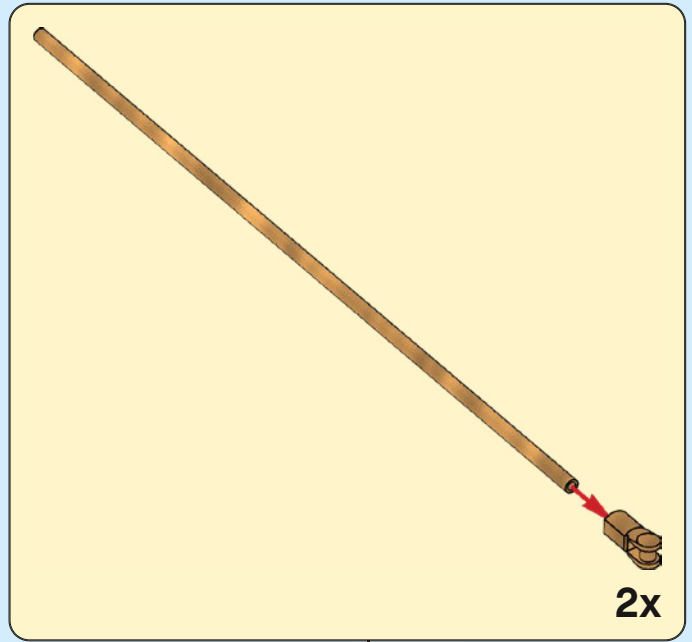

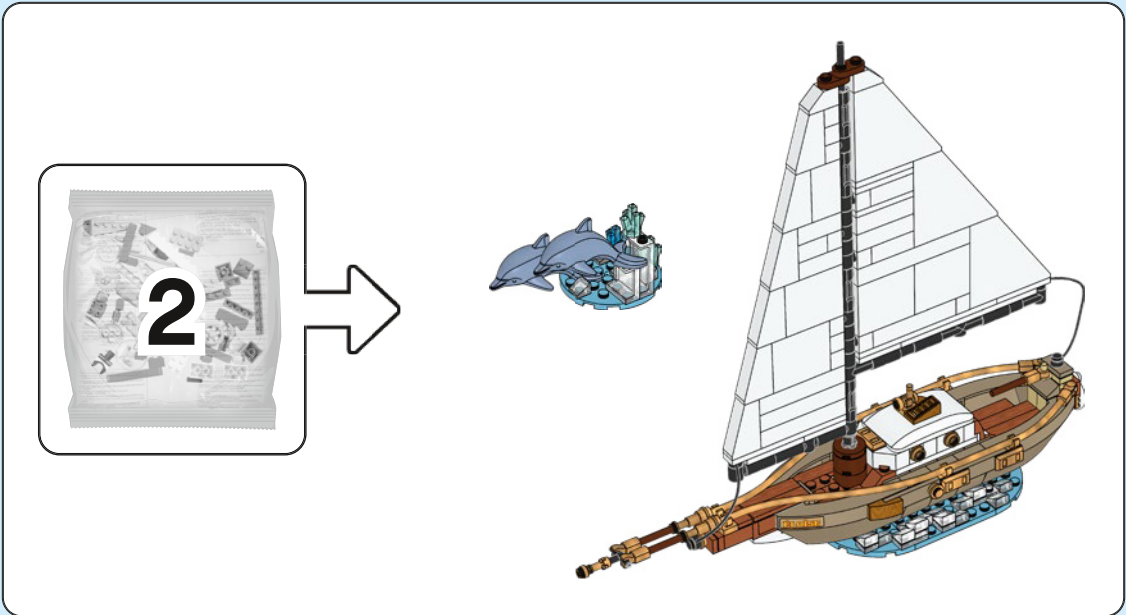

53

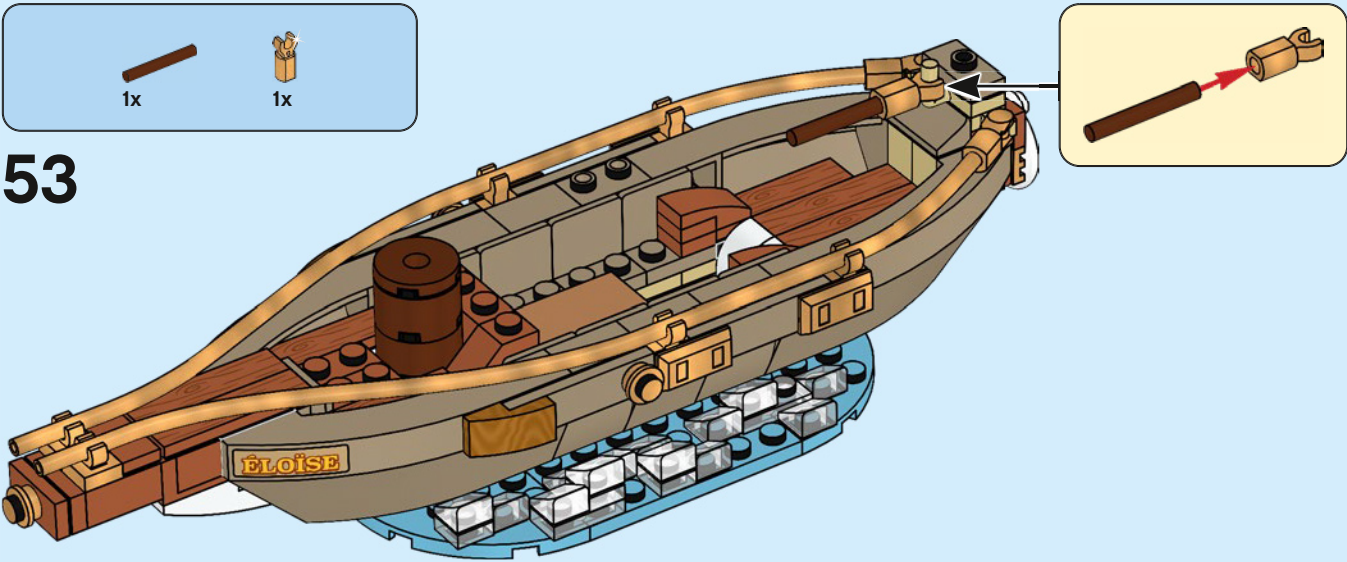

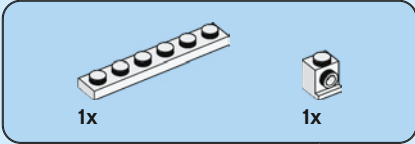
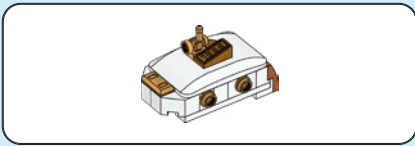

54

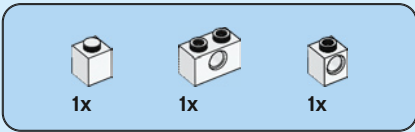
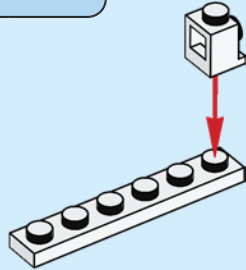

55

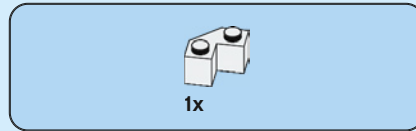
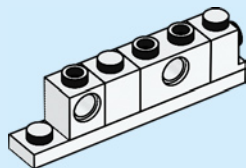

56

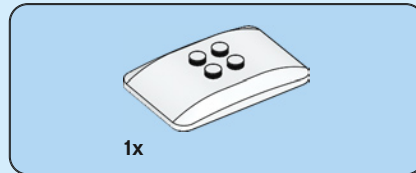
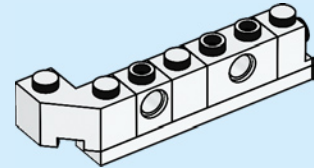

57

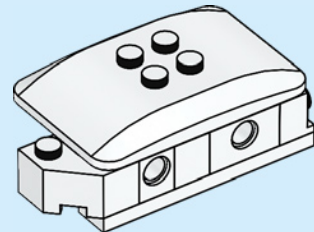



2x

# 58

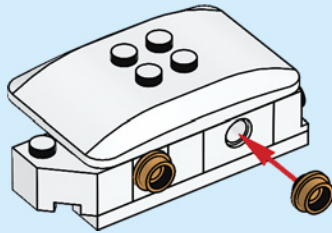

1x



1x



1x



1x



1x



1x

# 59

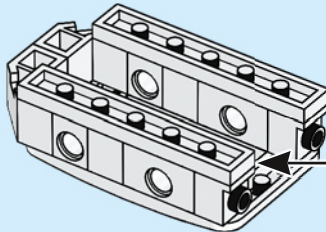

1

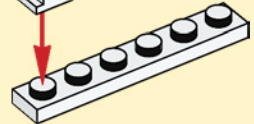

2

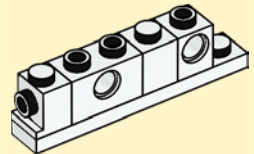

3

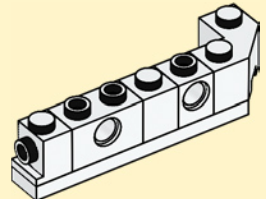





2x

60

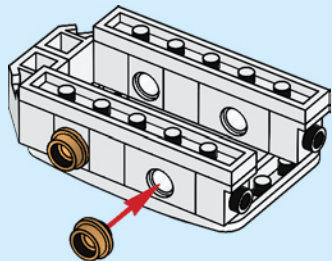

2x

61

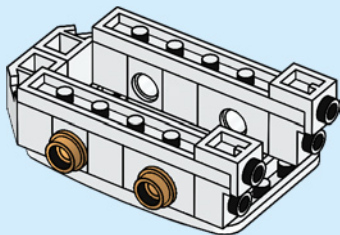

2x

62

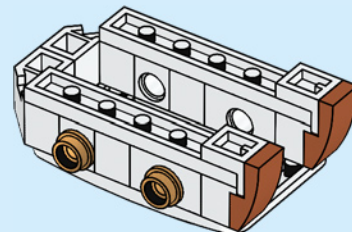

1x

63

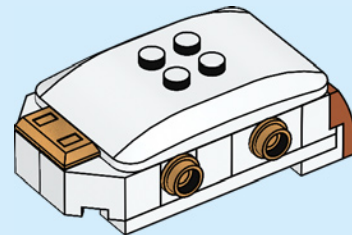

1x



1x

64

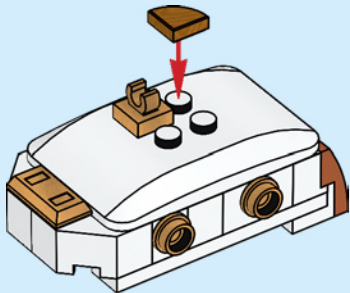

1x



1x

65

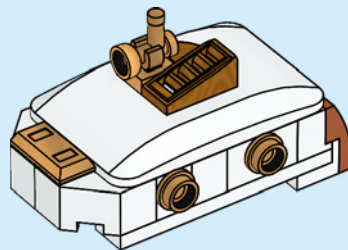

66

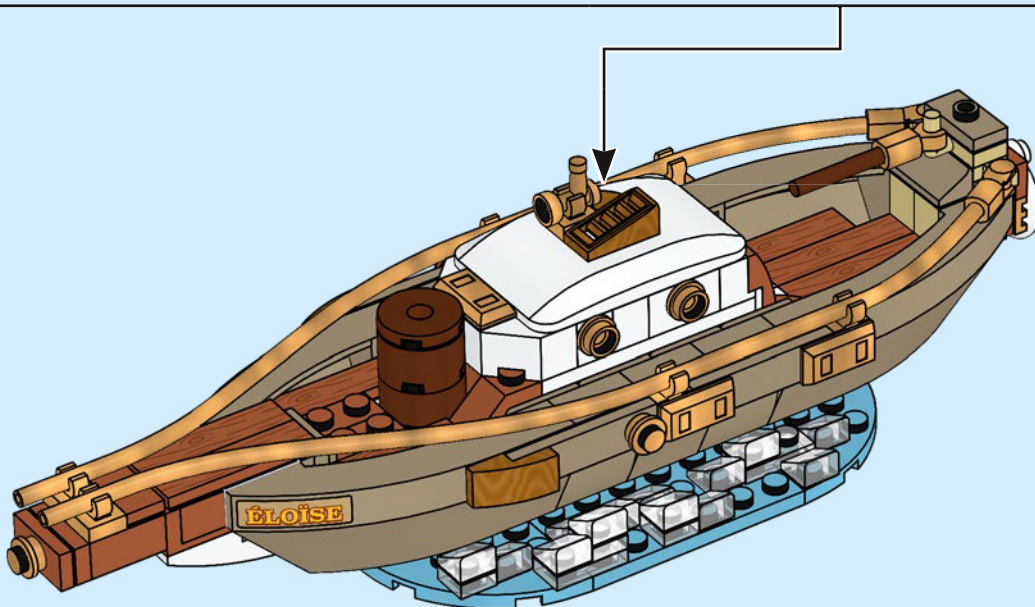

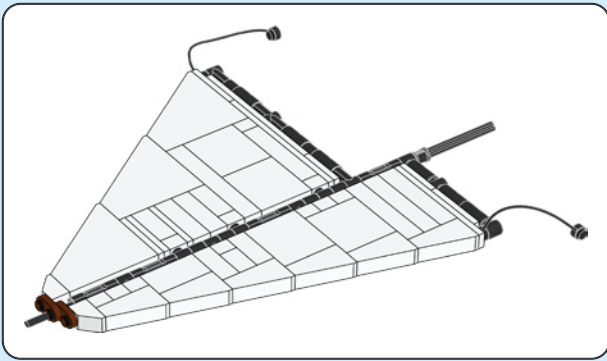

67

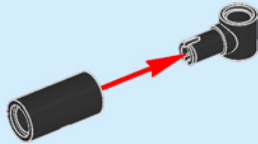

68

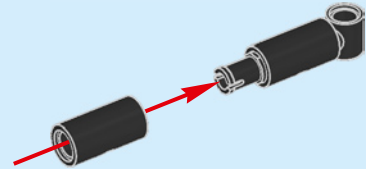

69

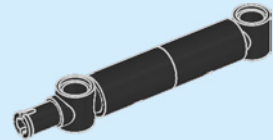



2x

70

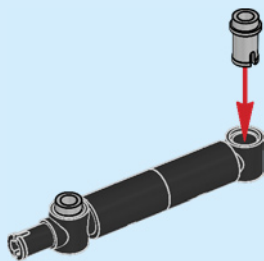

1x



1x

71

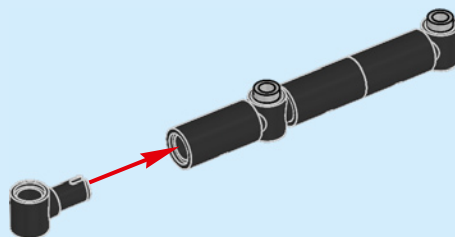

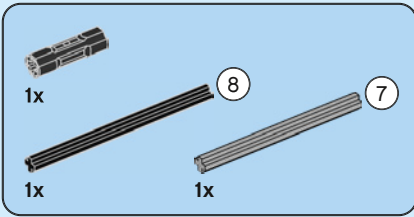

72

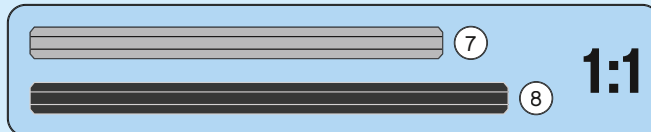
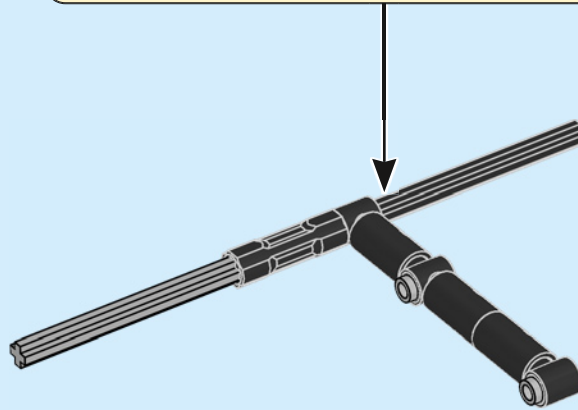
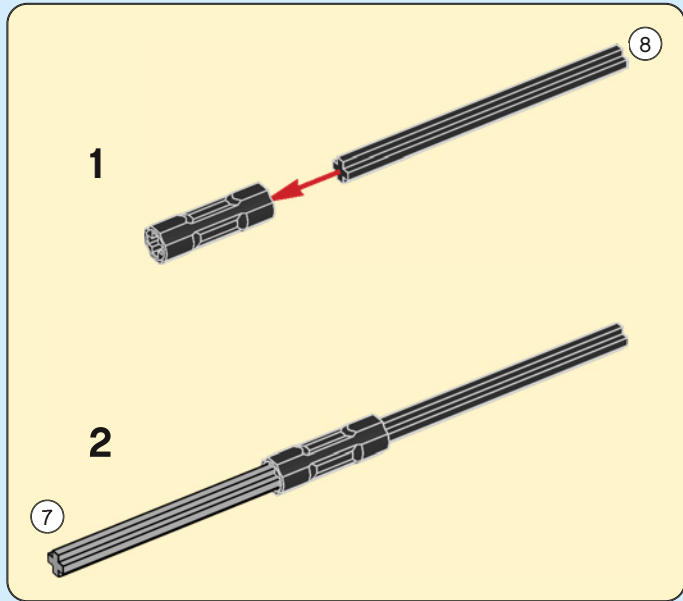



1x

73

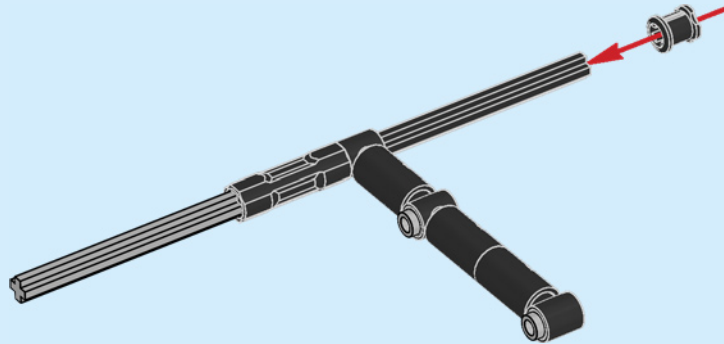

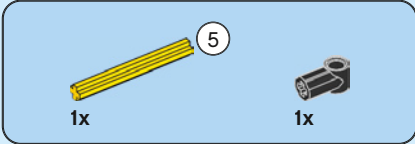

74

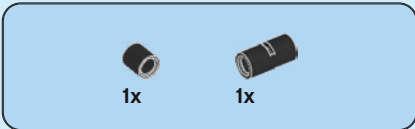
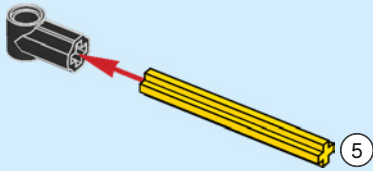

75

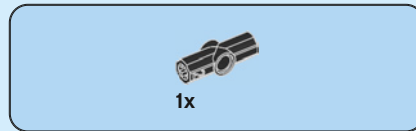
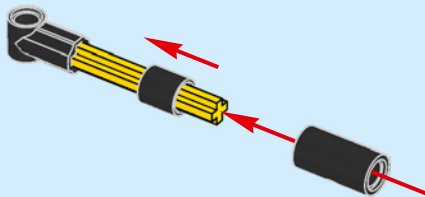

76

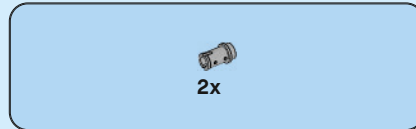
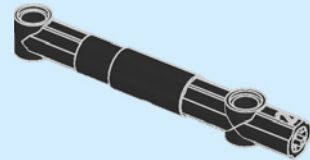

77

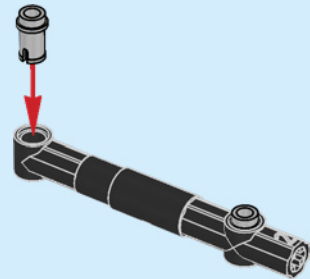

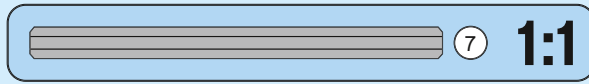
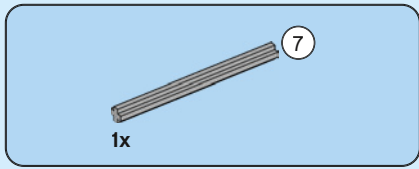

78

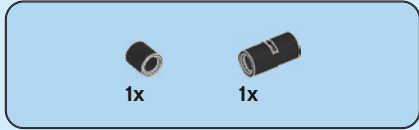
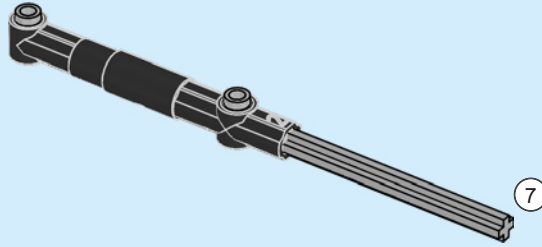

79

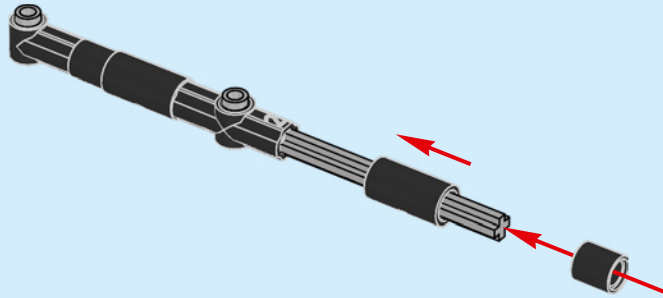





80

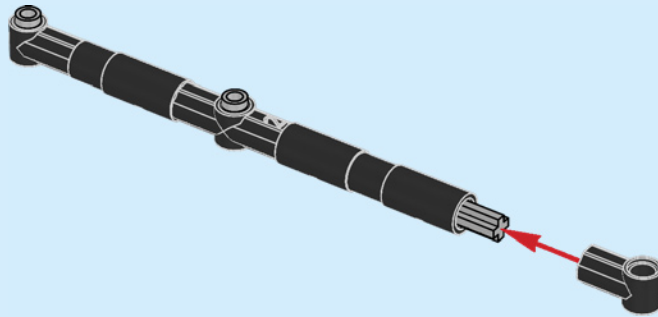

81

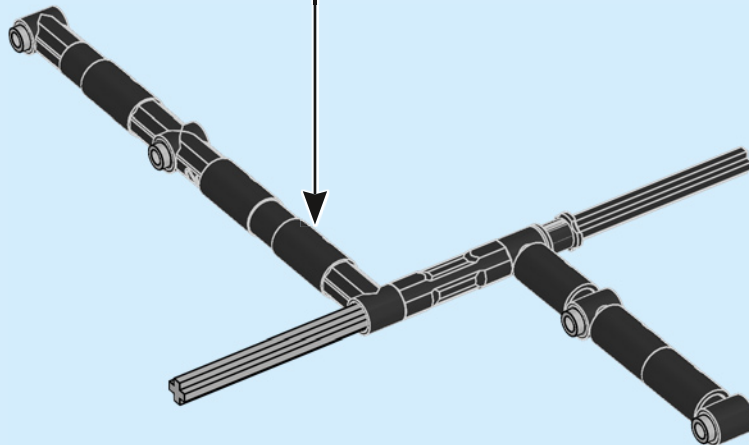



1x

82

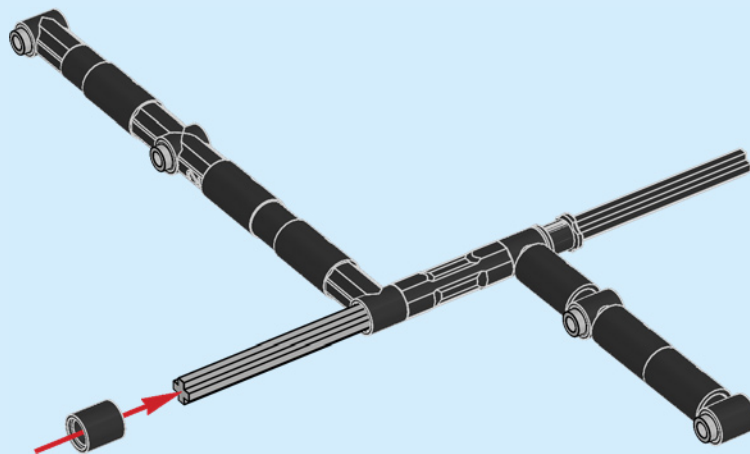

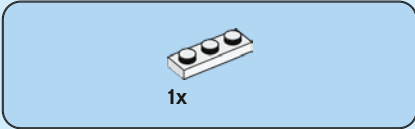
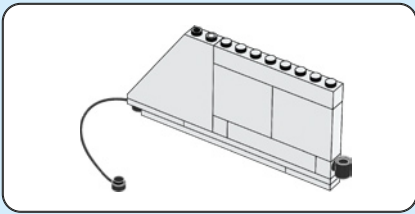

83

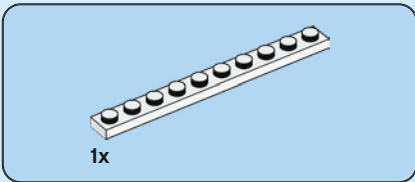
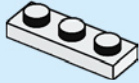

84

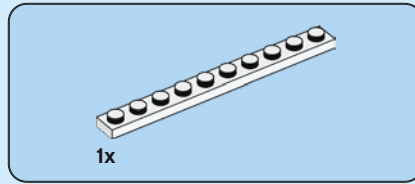
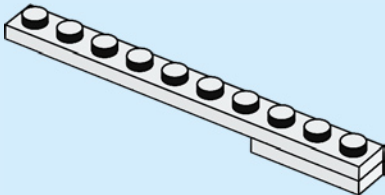

85

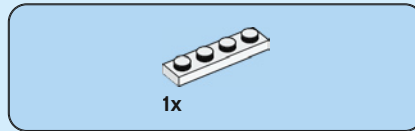
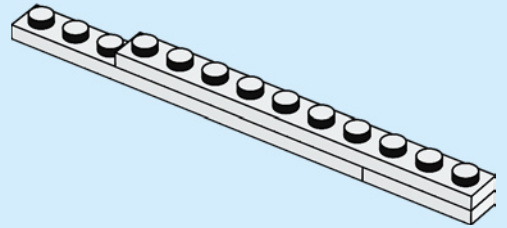

86

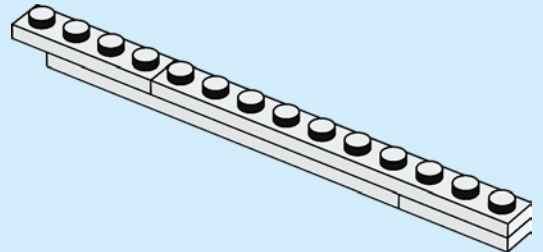

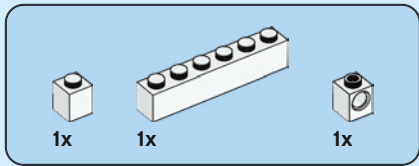

87

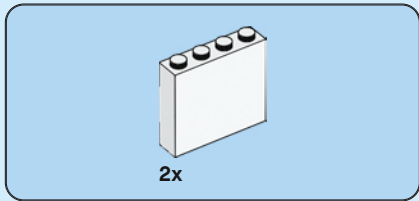
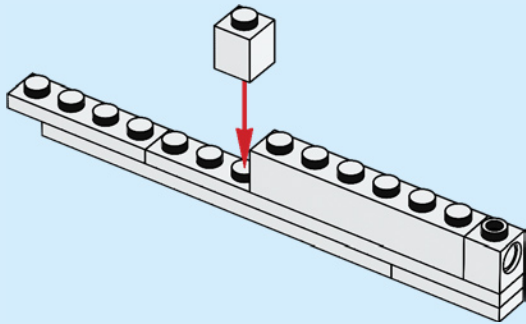

88

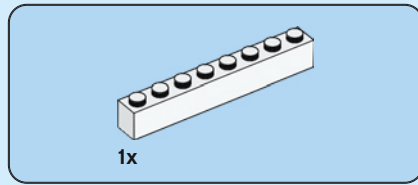
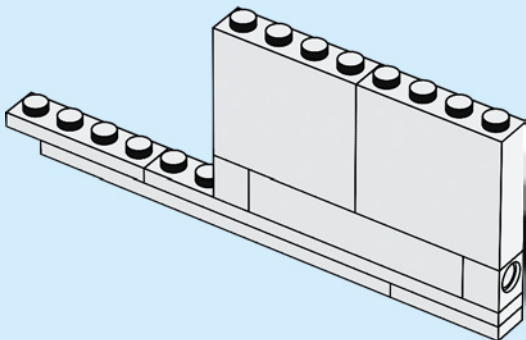

89

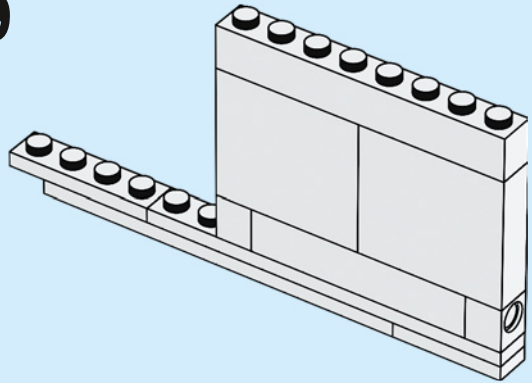

90

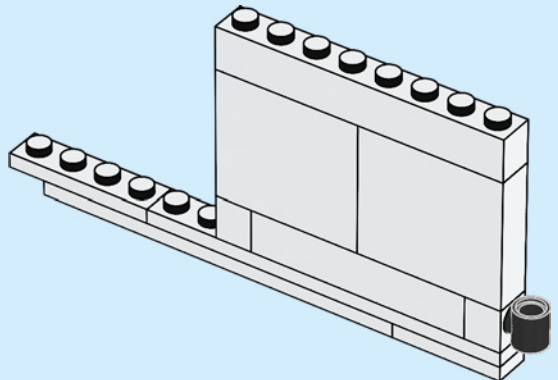

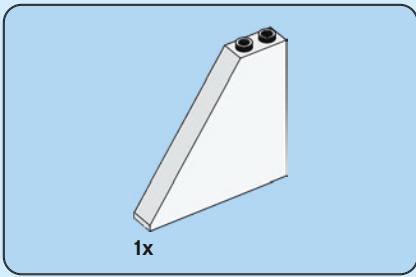

91

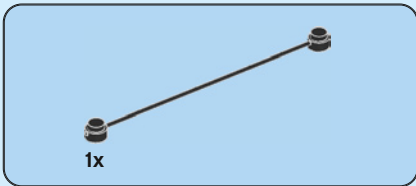
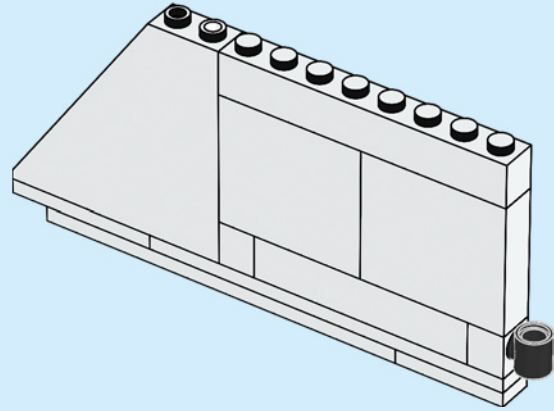

92

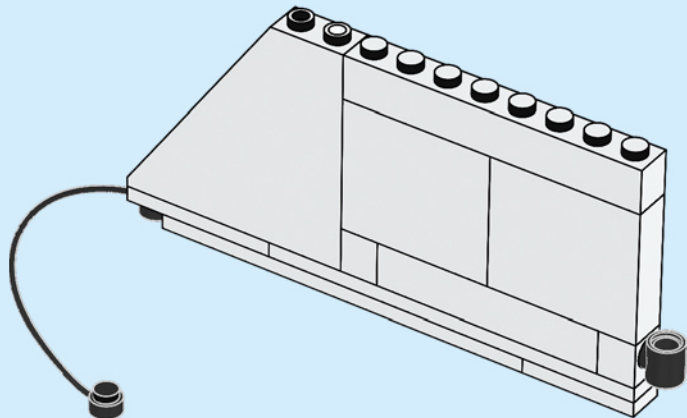

93

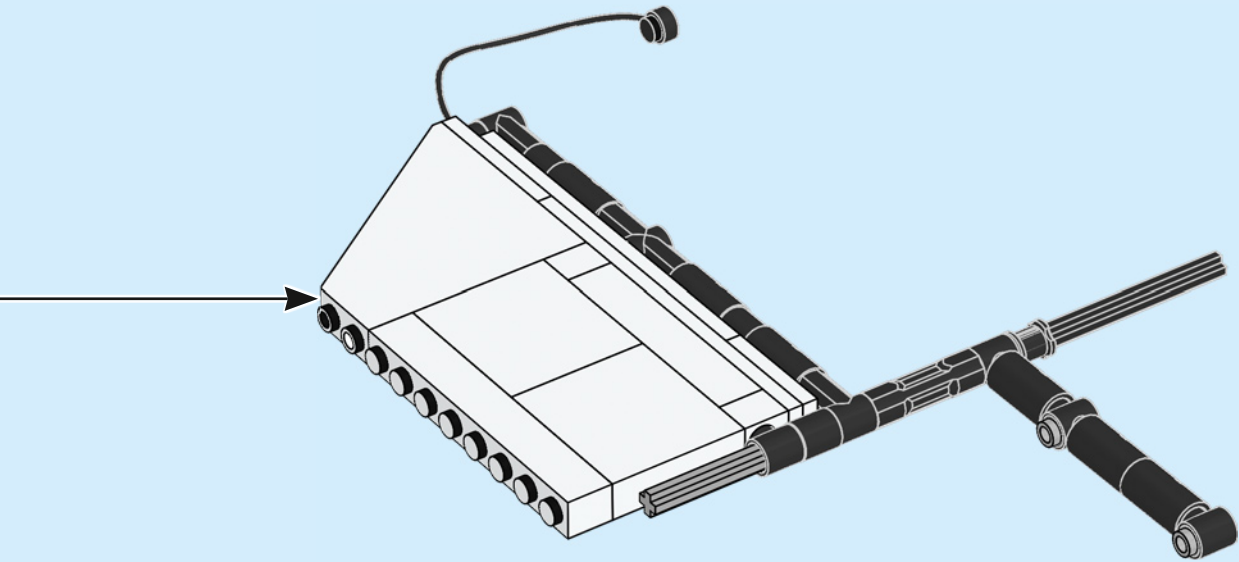



1x

94

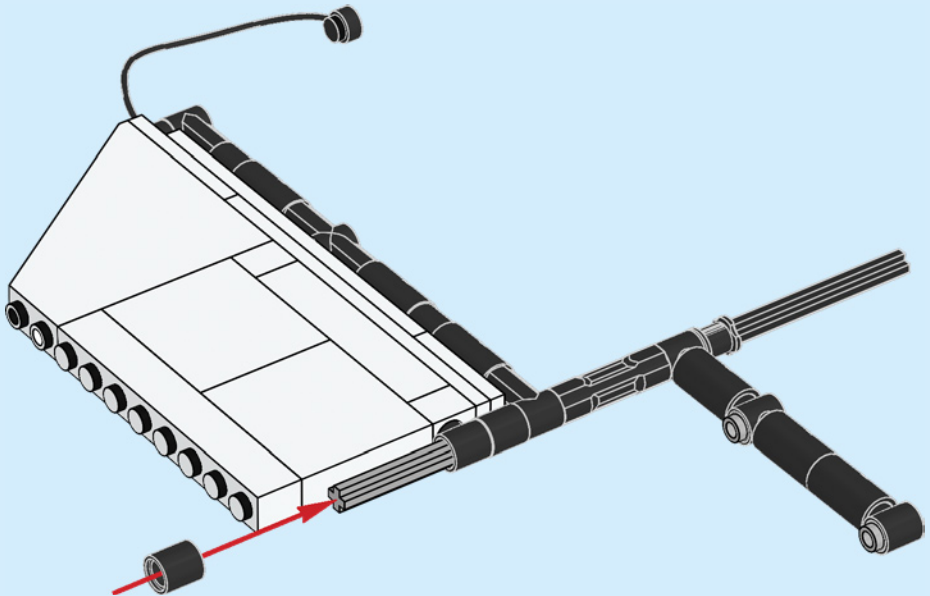

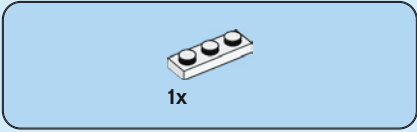
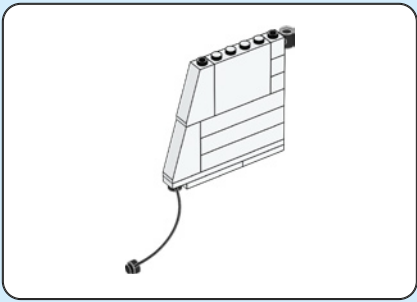

95

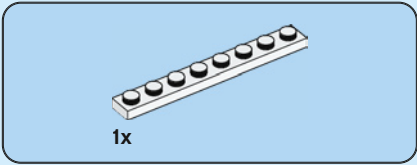
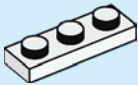

96

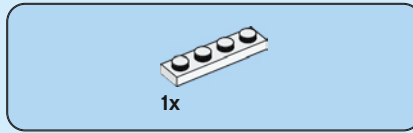
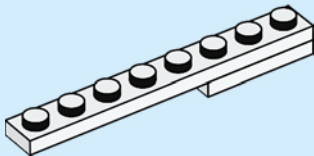

97

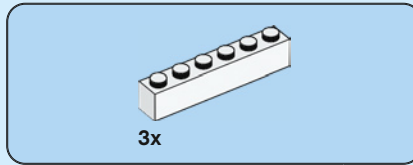
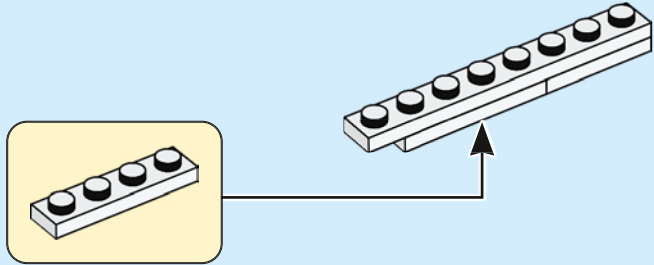

98

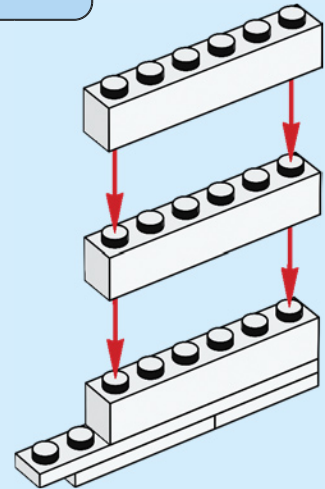



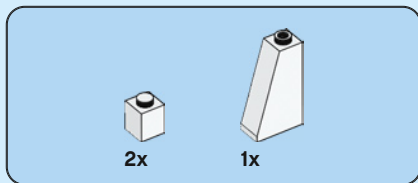

99

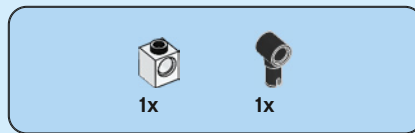
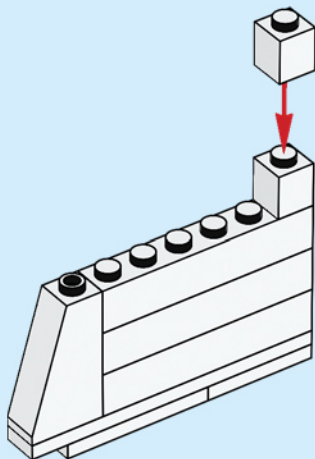

100

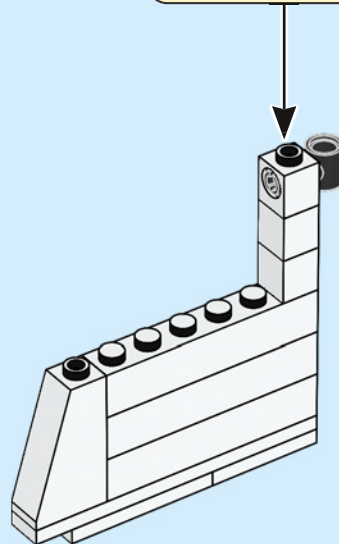
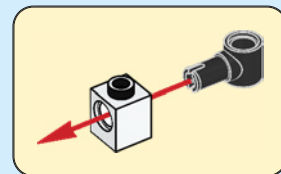

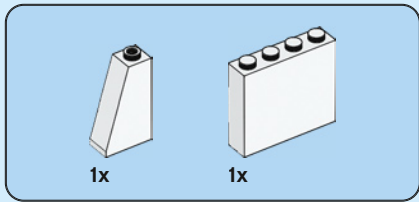

101

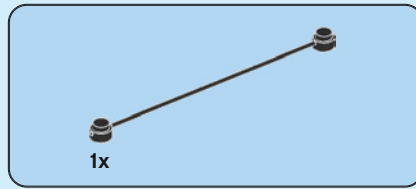
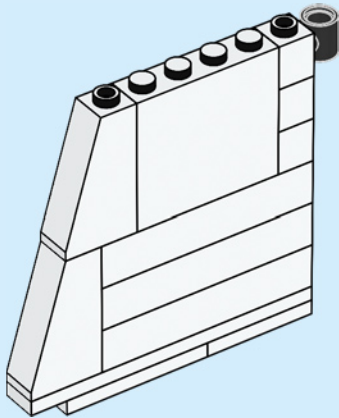

102

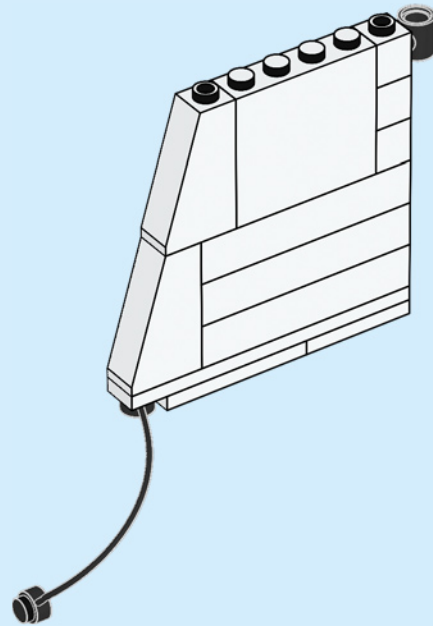

103

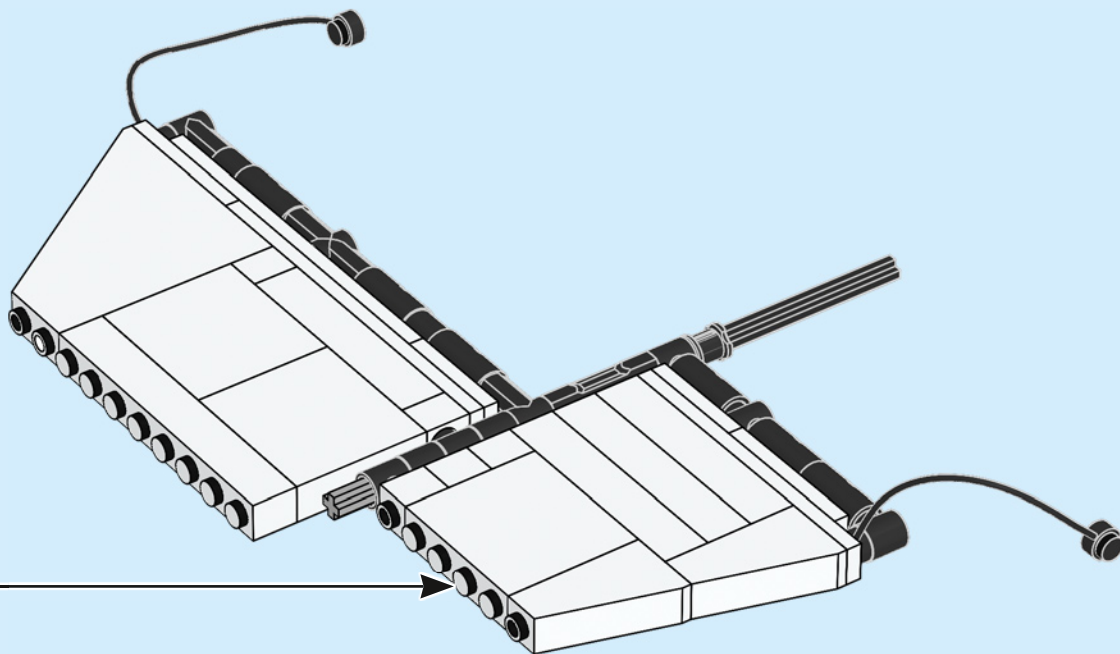

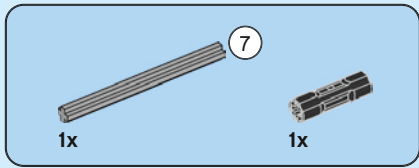

104

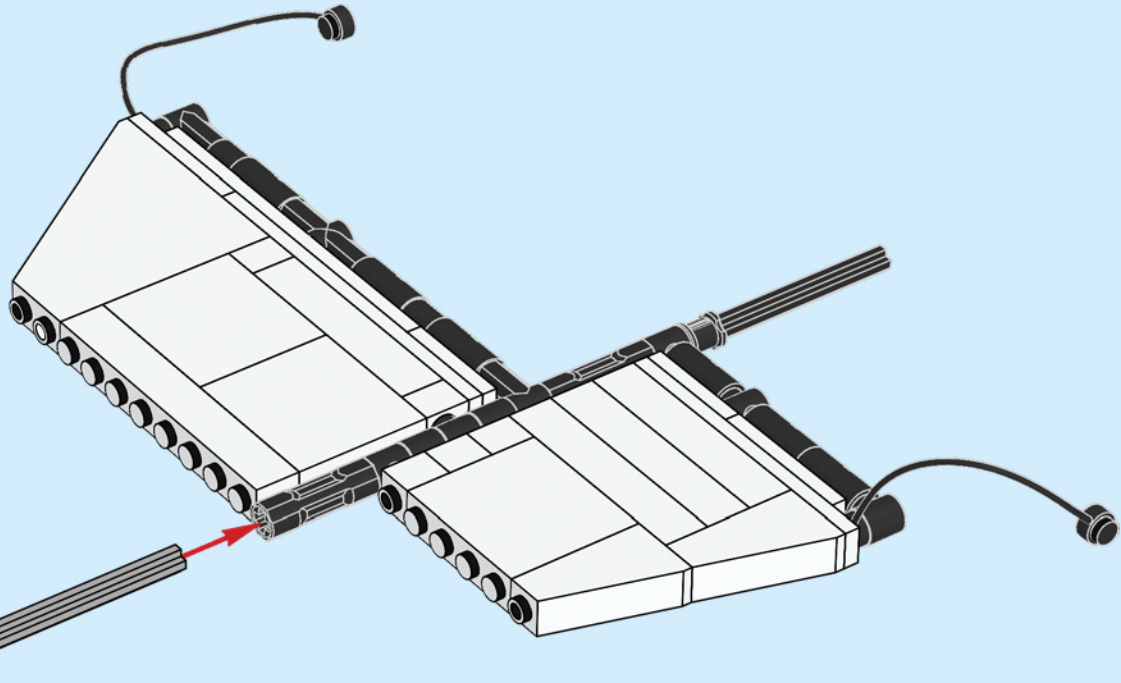

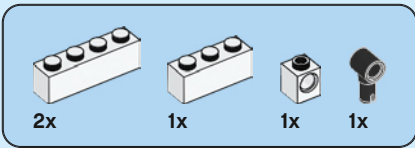

# 105

1

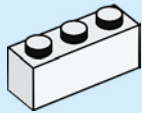

2

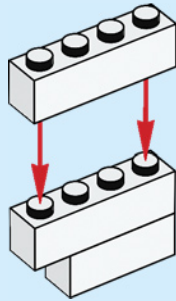

3

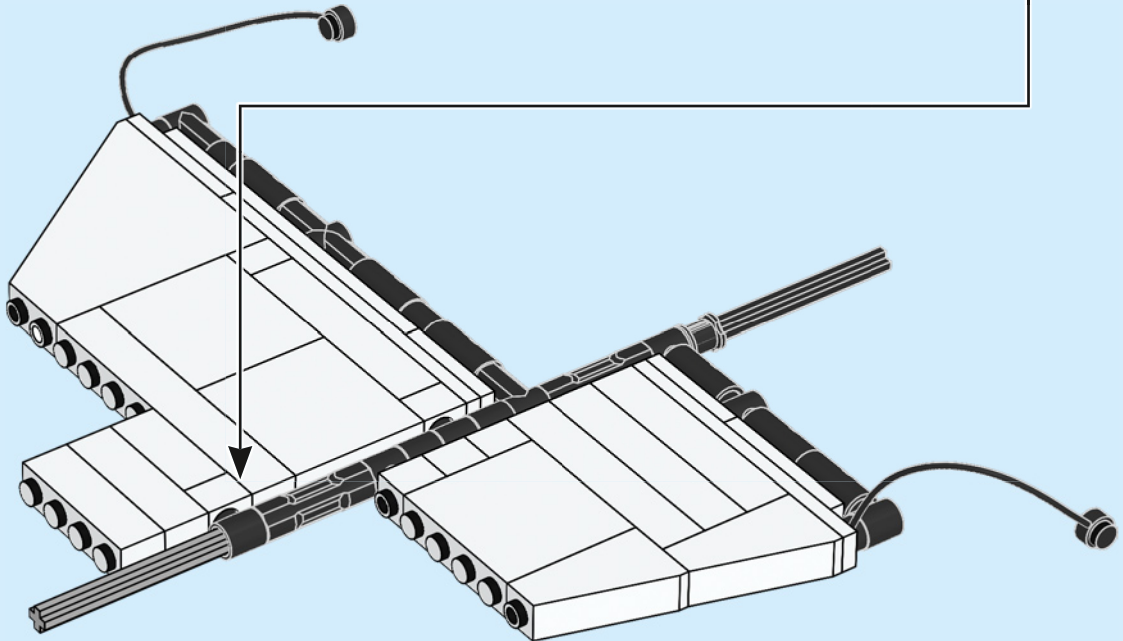
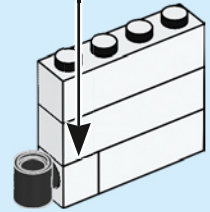
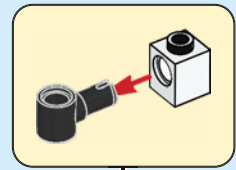

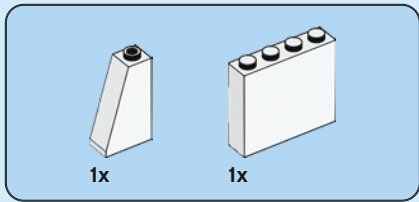

106

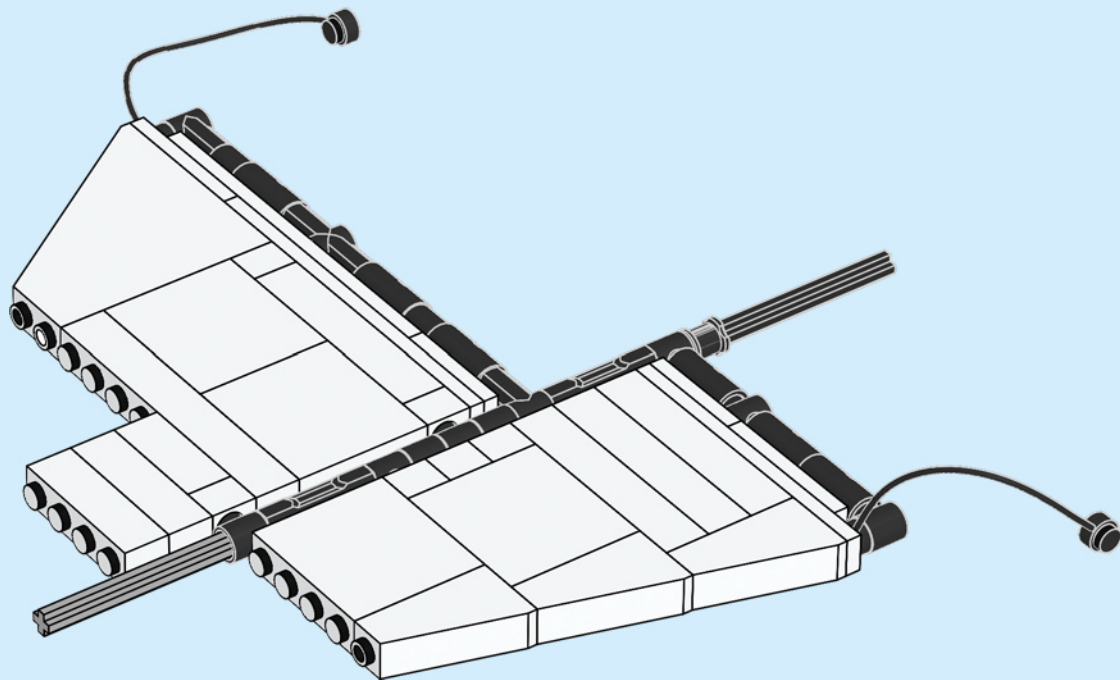



1x

107

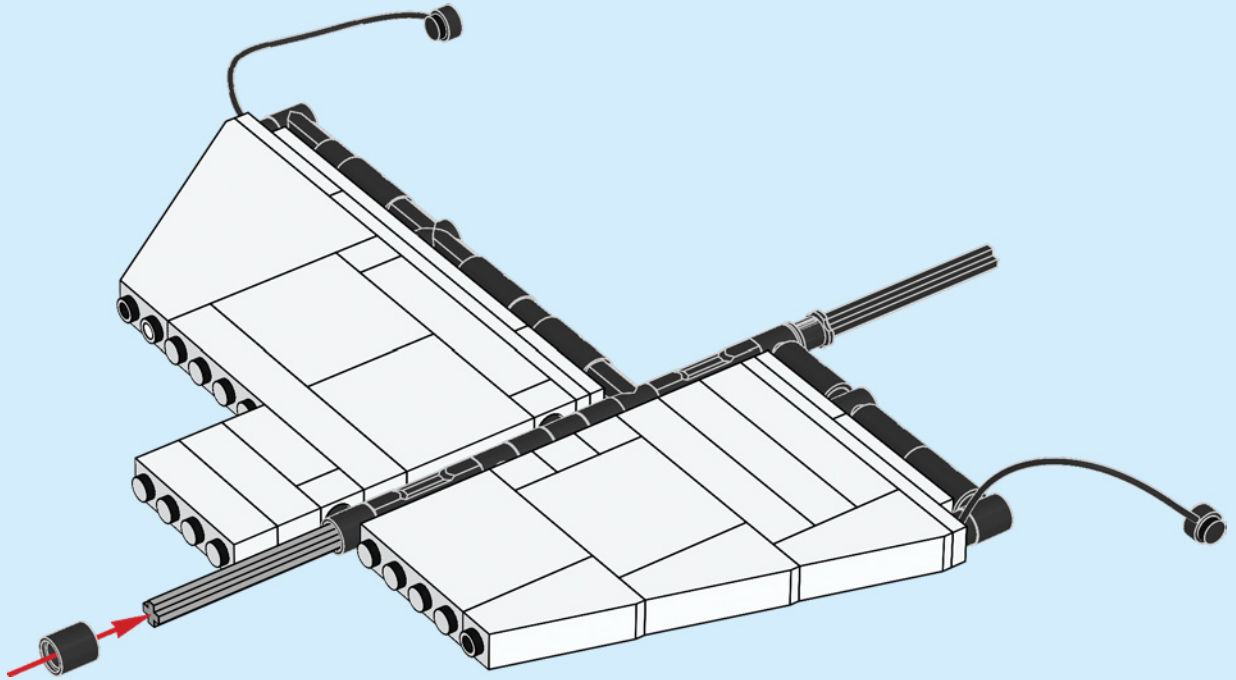

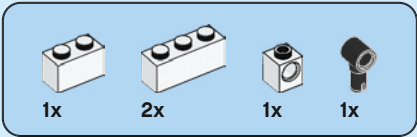

108

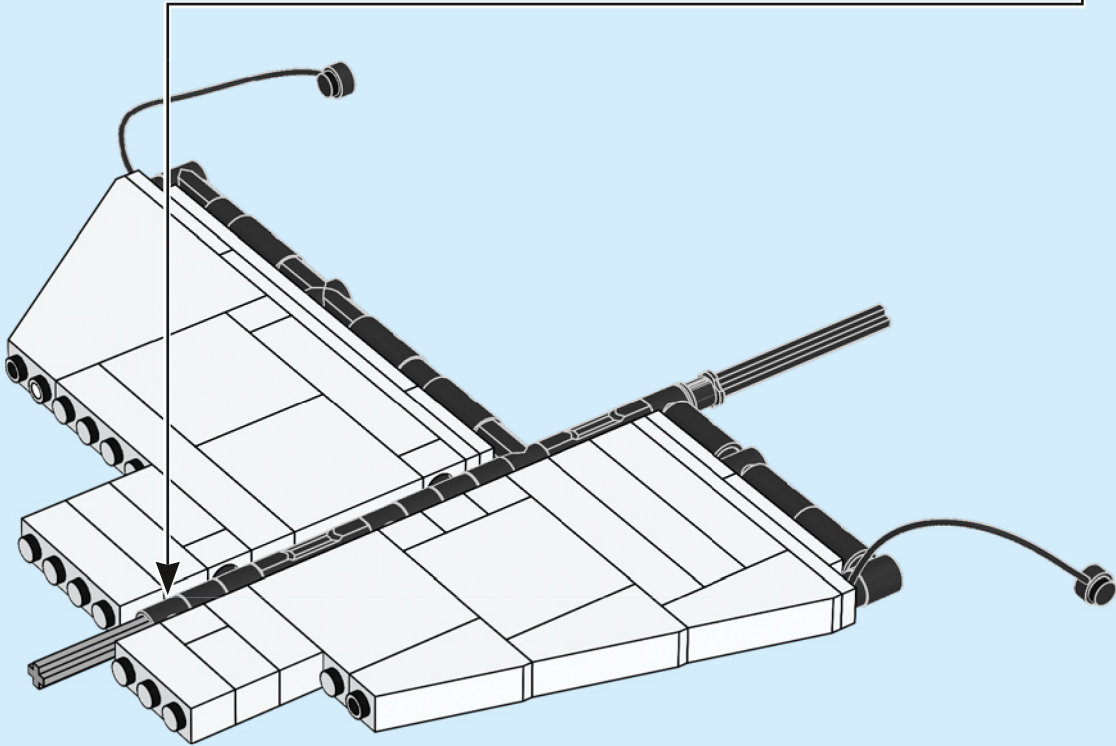
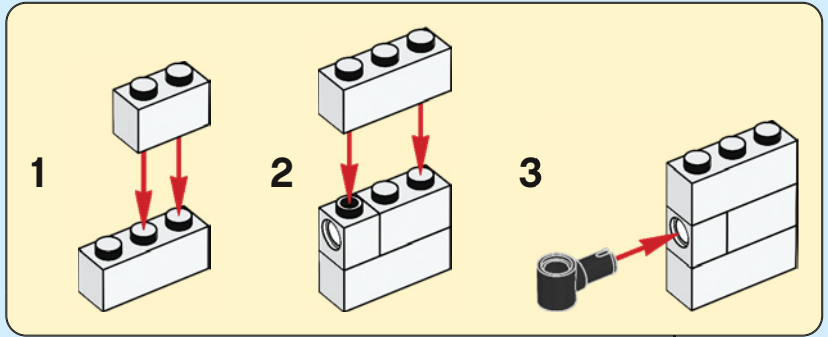





1x

109

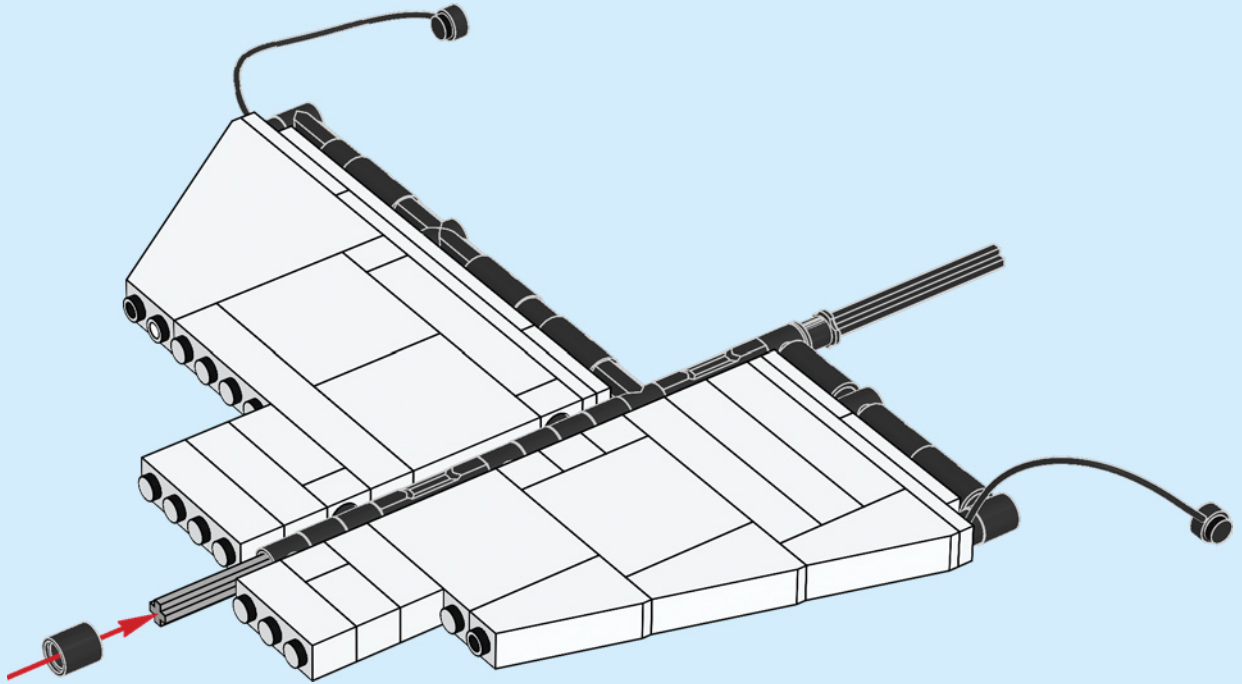

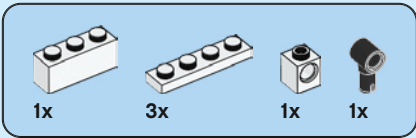

# 110

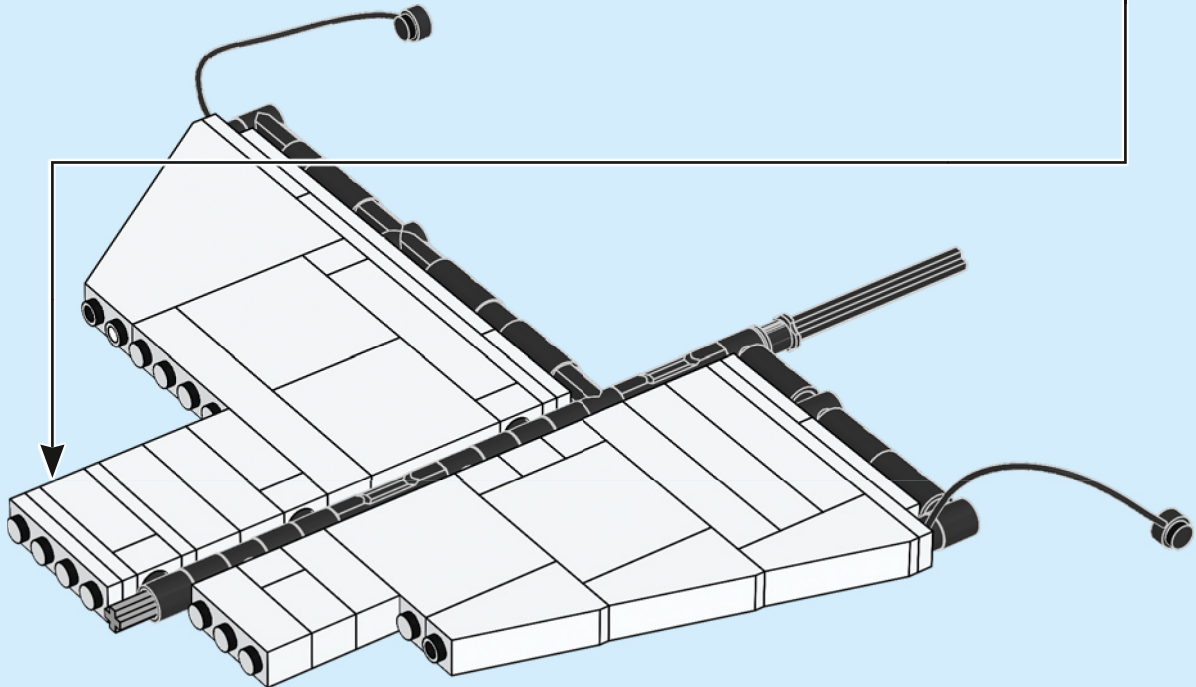
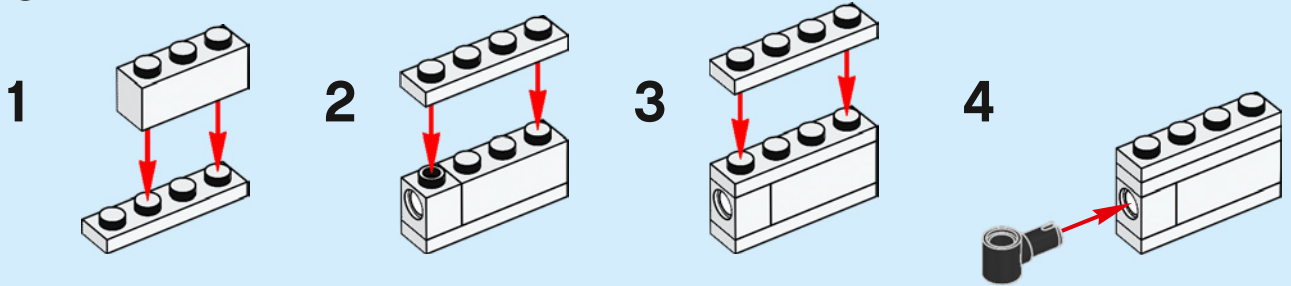

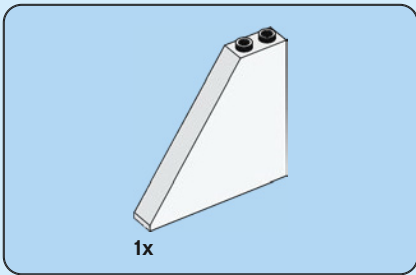

111

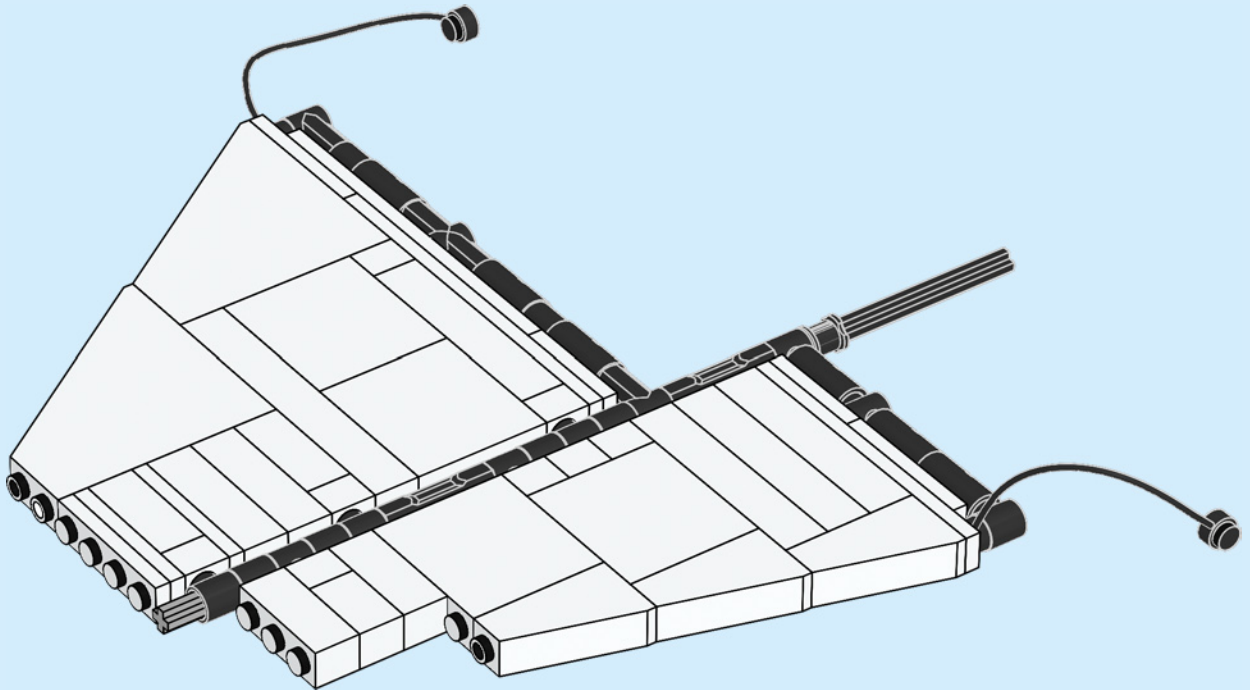

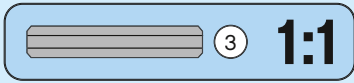
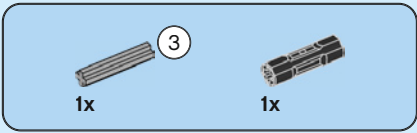

112

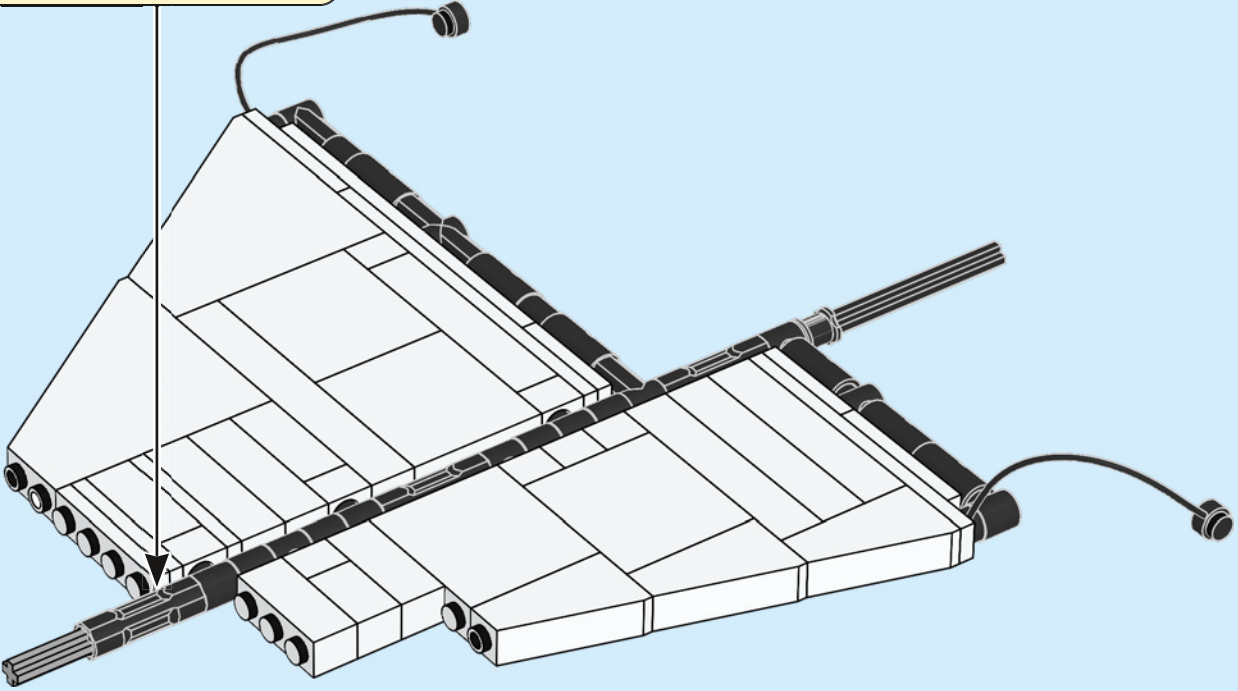
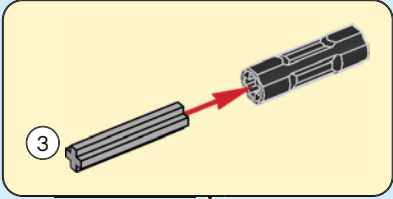

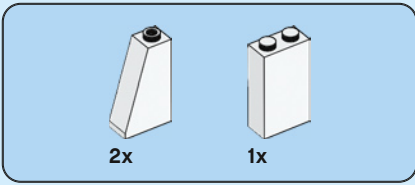

113

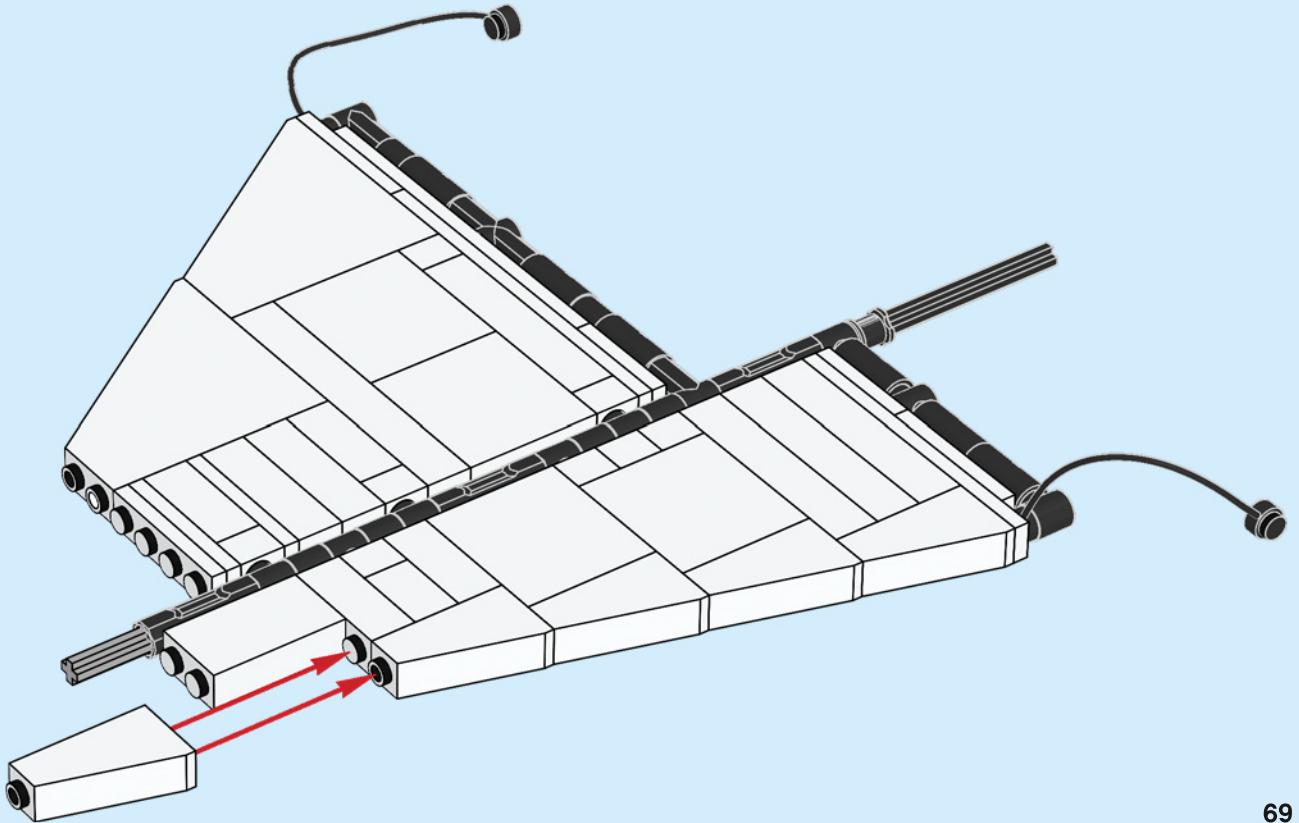

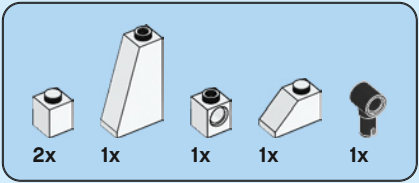

114

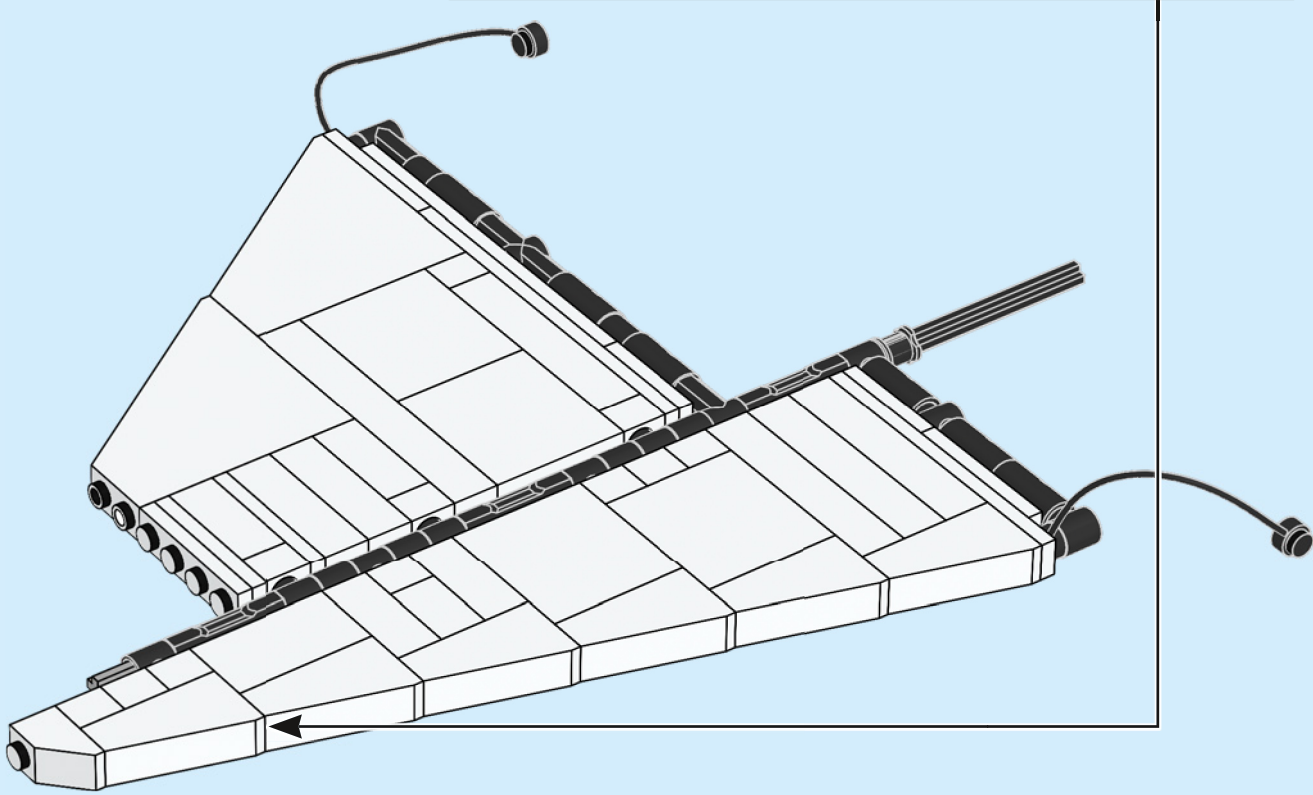
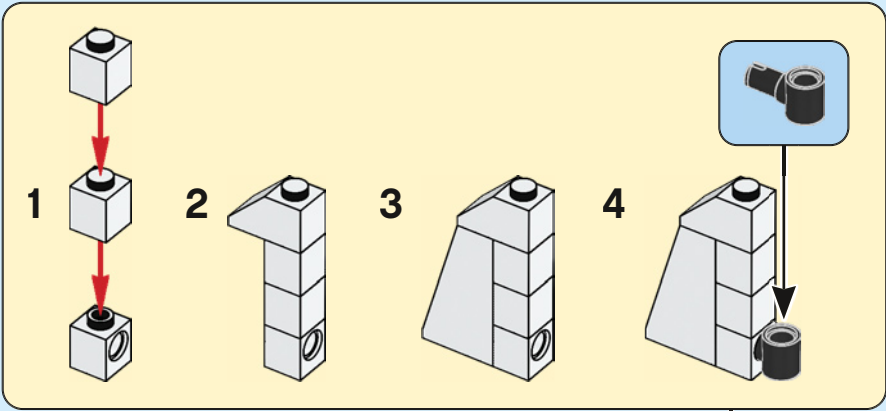

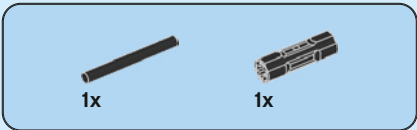

115

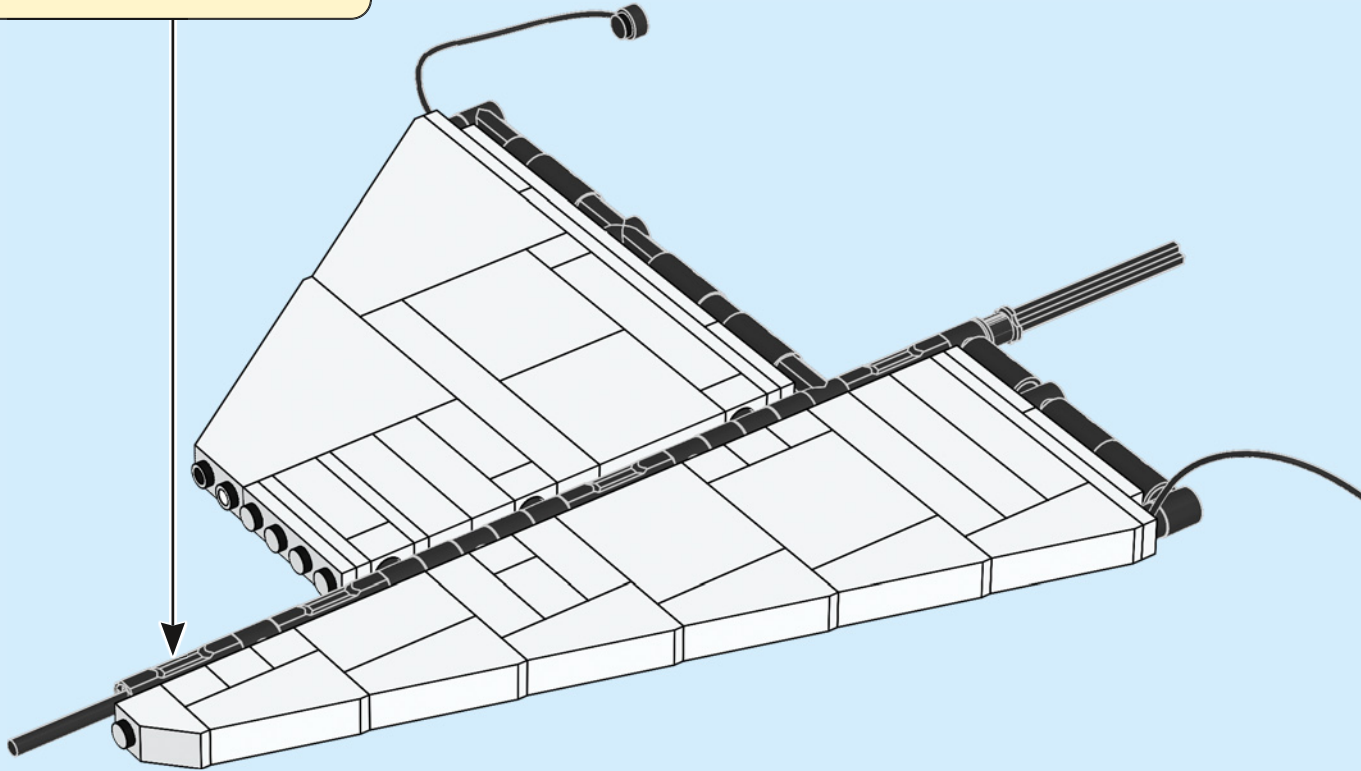
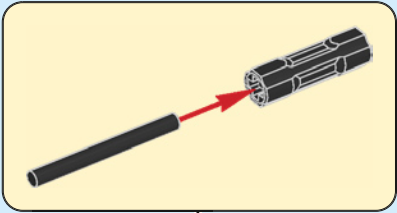

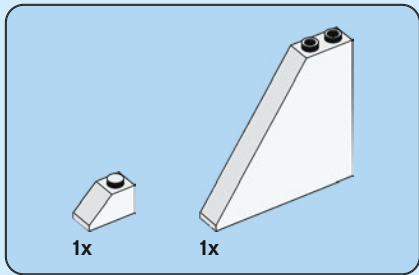

116

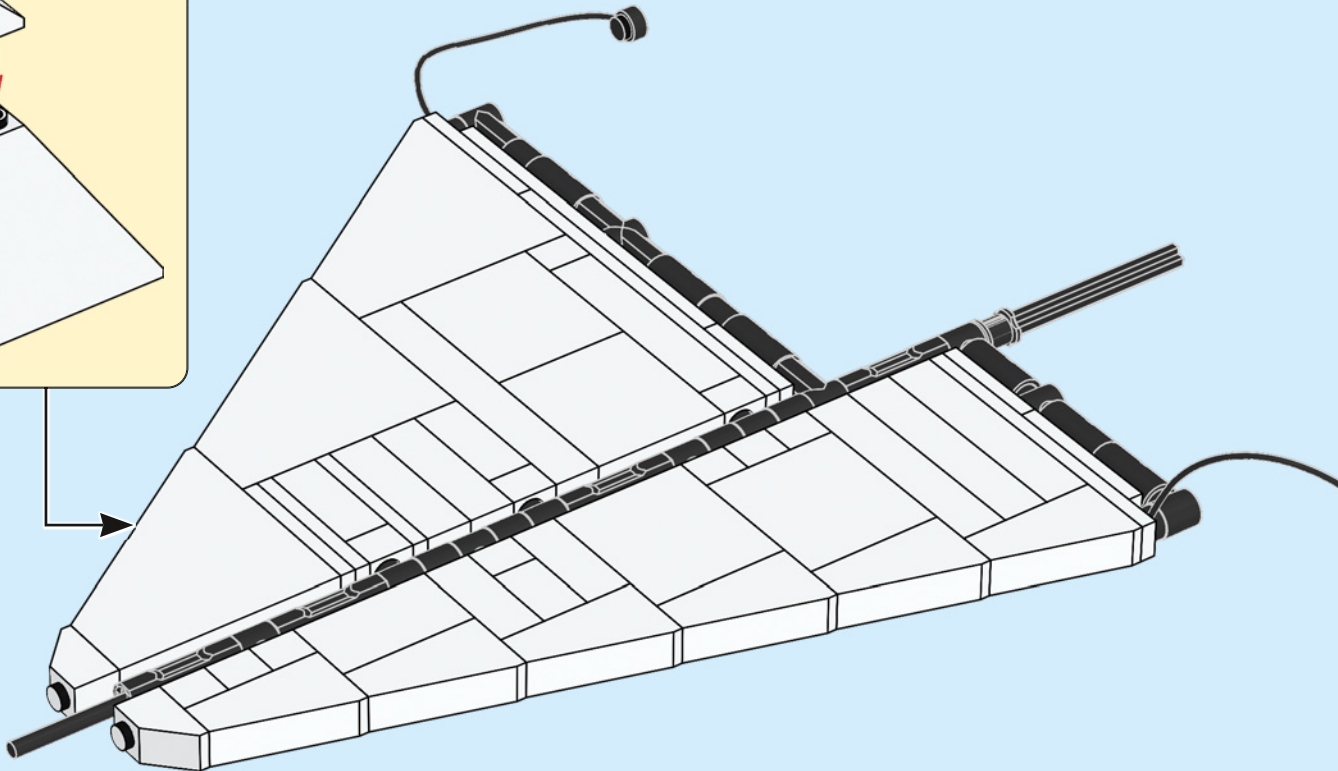
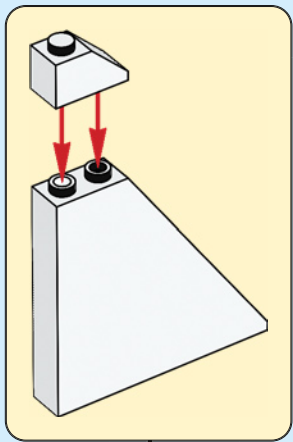





2x

117

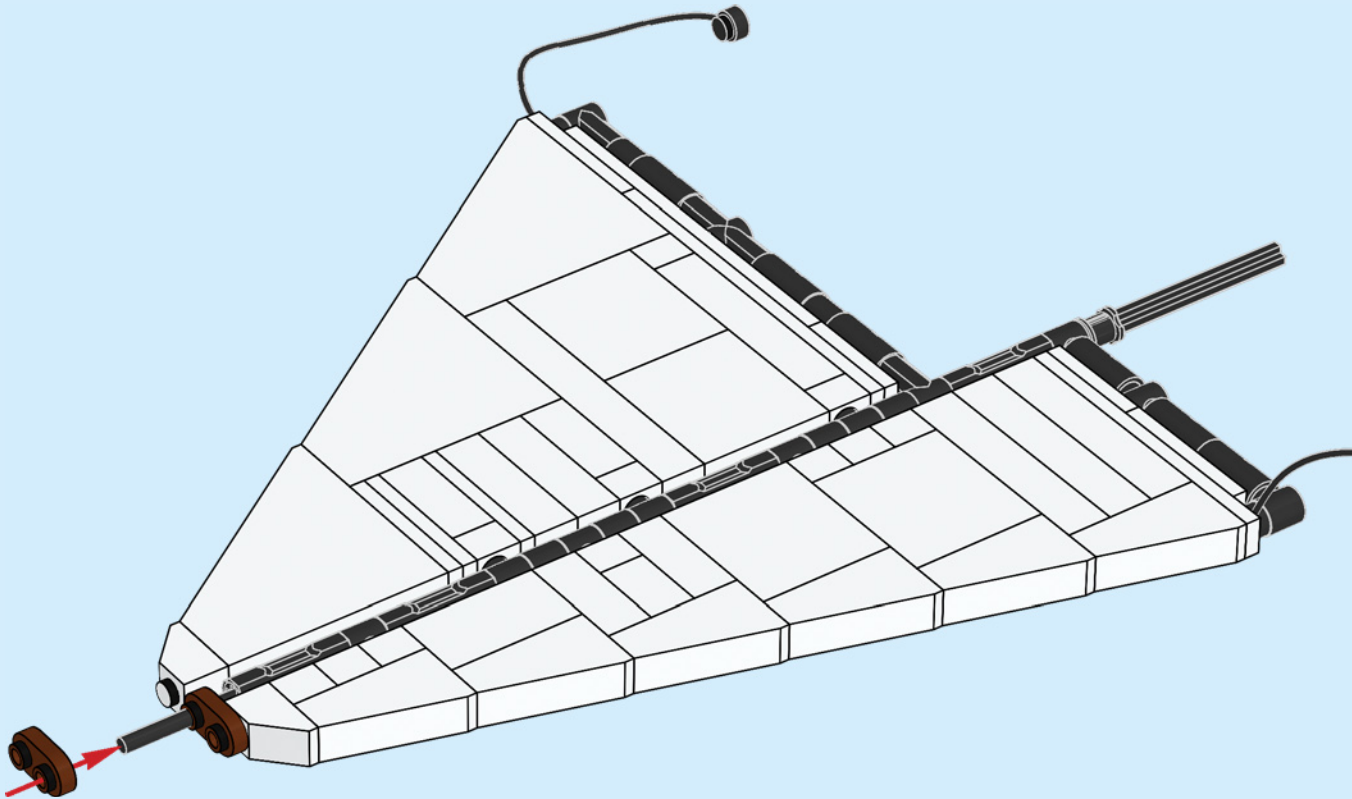

118

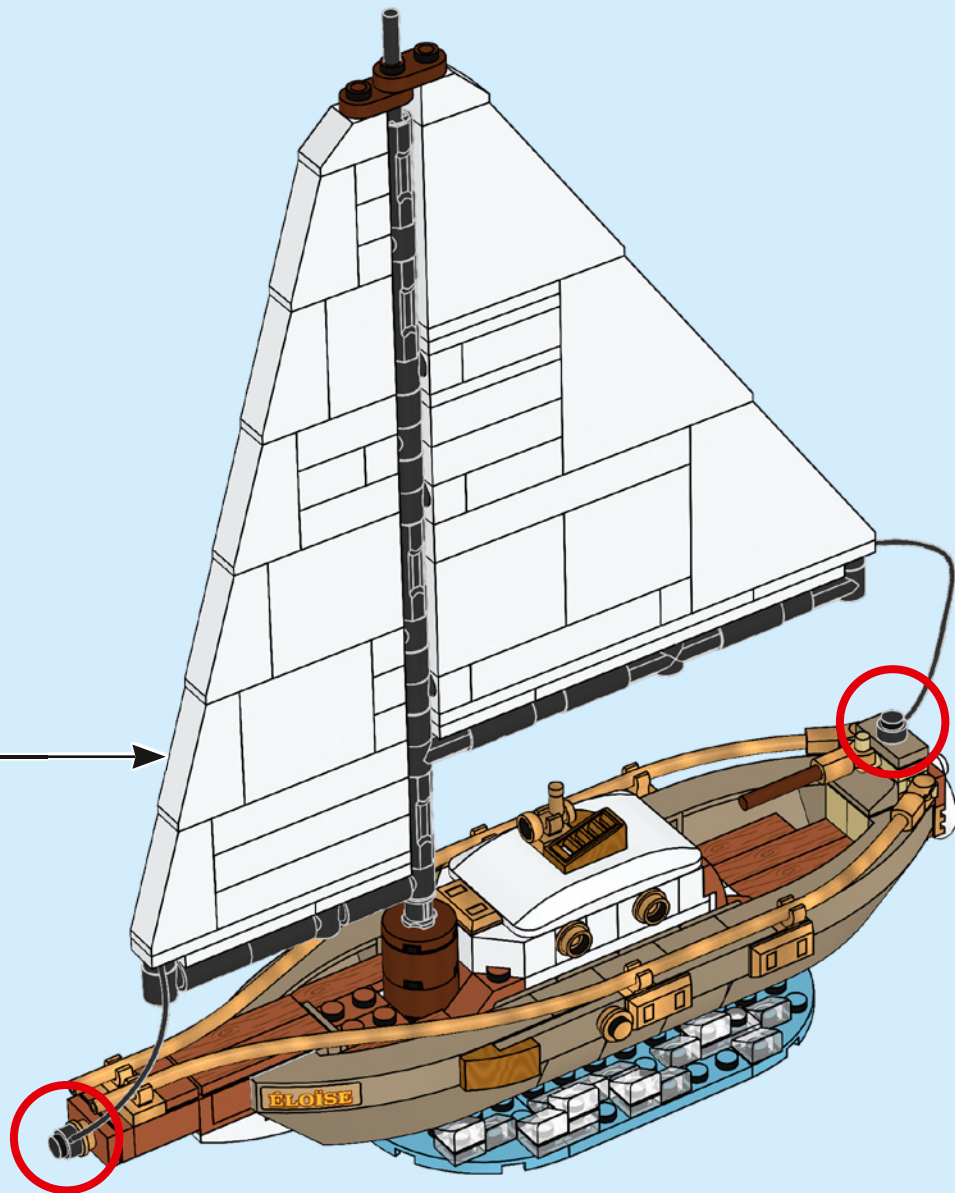

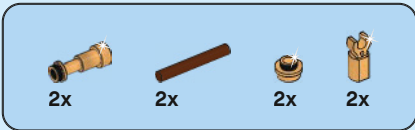

# 119

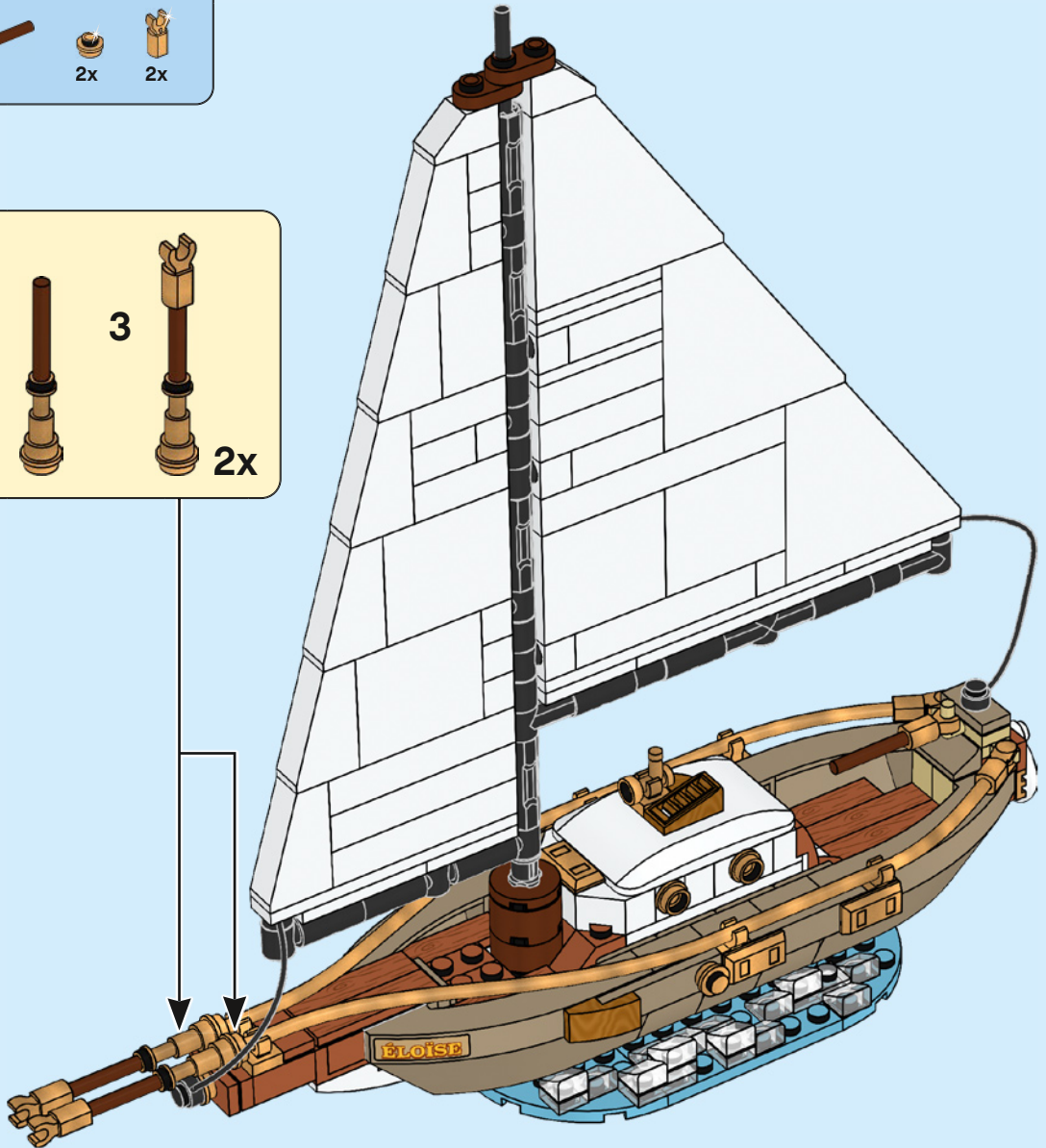
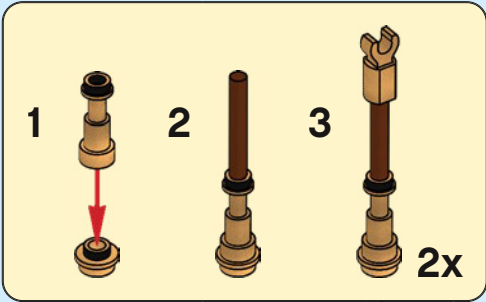



1x



1x

# 120

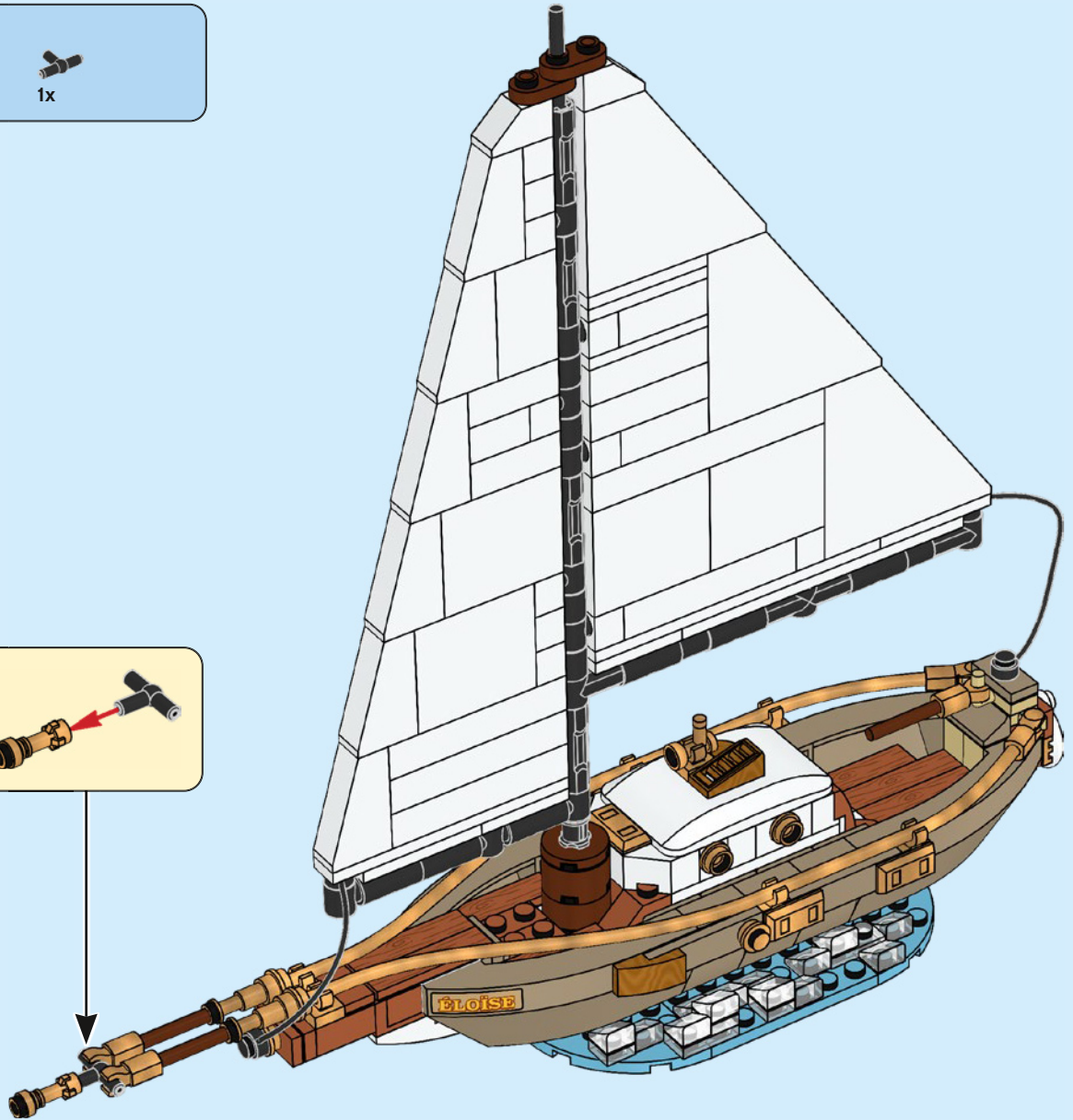
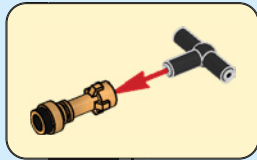

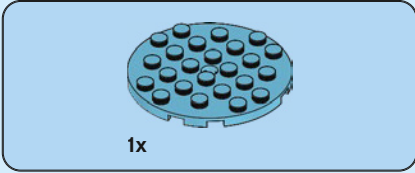
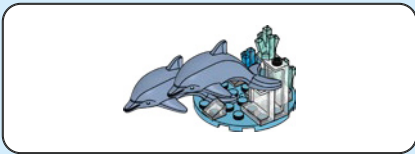

1

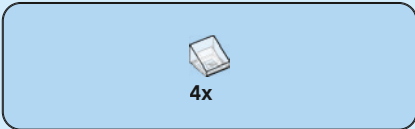
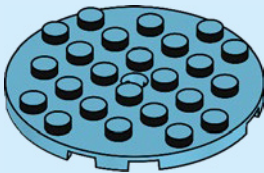

2



3

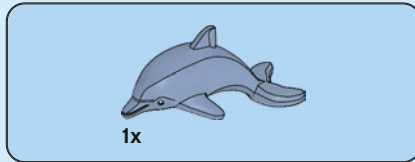
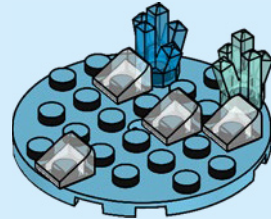

4

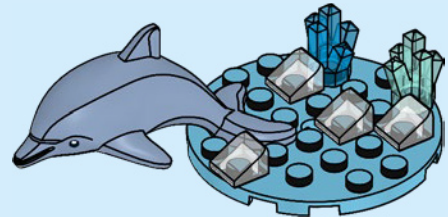

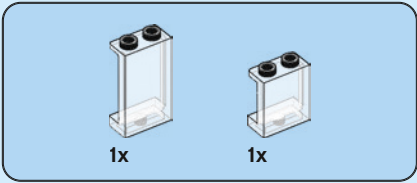

5

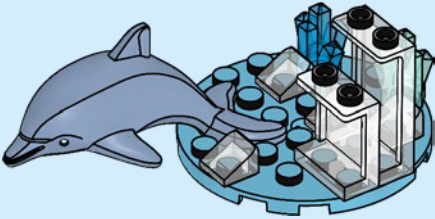

6

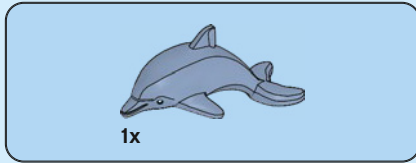
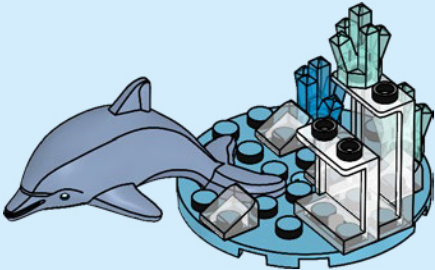

7

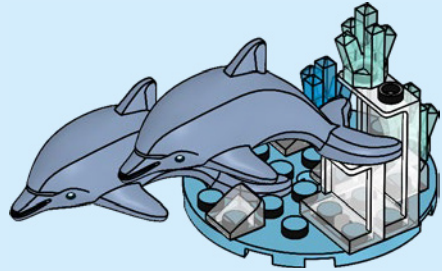

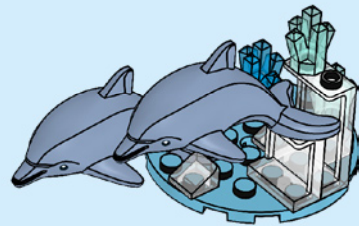
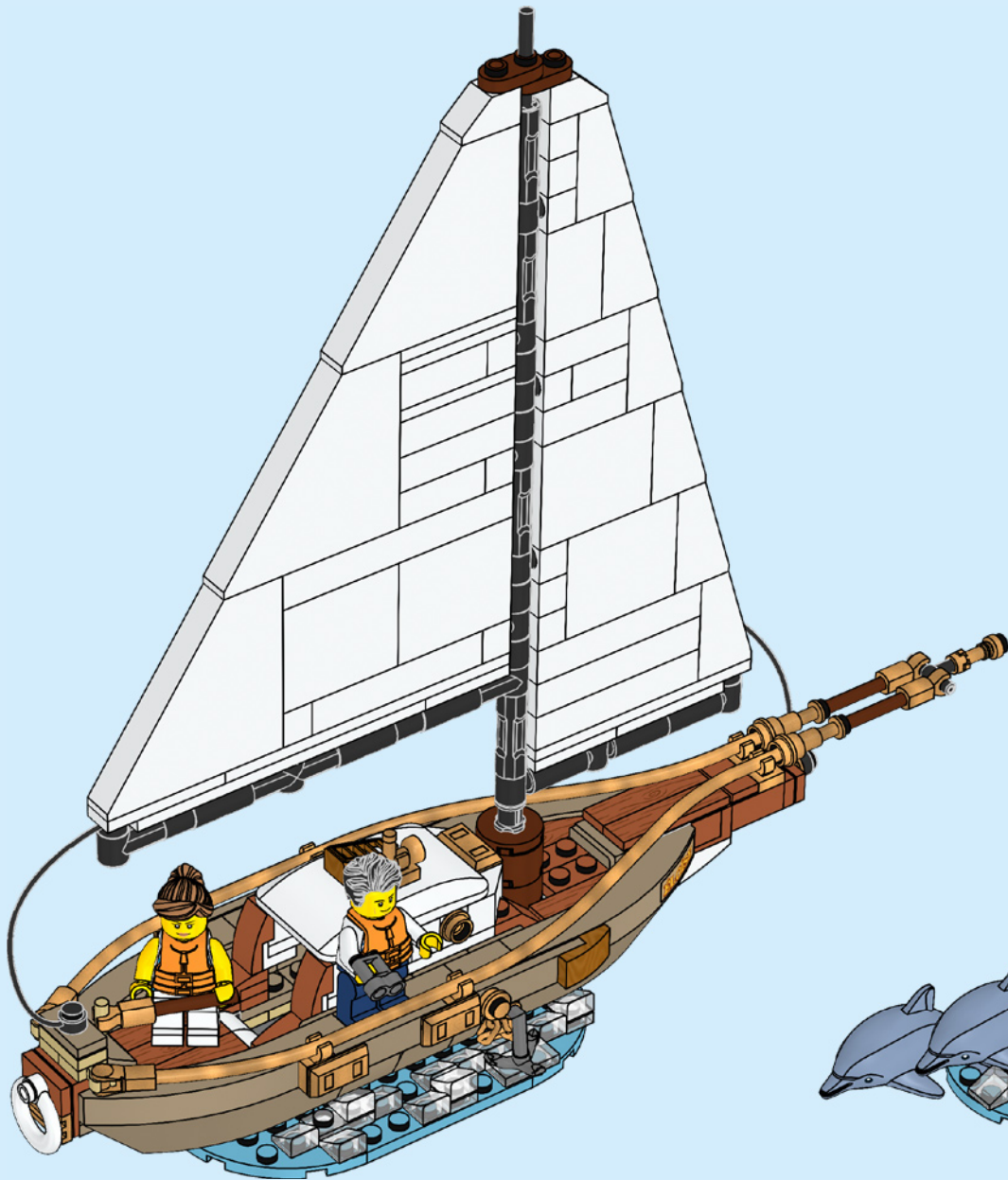



# IDEAS

GATHER SUPPORT  
HOL DIR UNTERSTÜTZUNG  
RASSEMBLE DES VOTES  
CHIEDI DI ESSERE SUPPORTATO  
GANA APOYOS  
OBTÉM APOIO  
SZEREZZ TÁMOGATÁST  
IEGŪSTI ATBALSTU  
获得更多支持

SHARE YOUR IDEA  
TEILE DEINE IDEE  
PARTAGE TON IDÉE  
CONDIVIDI LA TUA IDEA  
COMPARTE TU IDEA  
PARTILHA A TUA IDEIA  
TEDD KÖZZÉ AZ ÖTLETED  
DALIES AR SAVU IDEJU  
分享您的观点

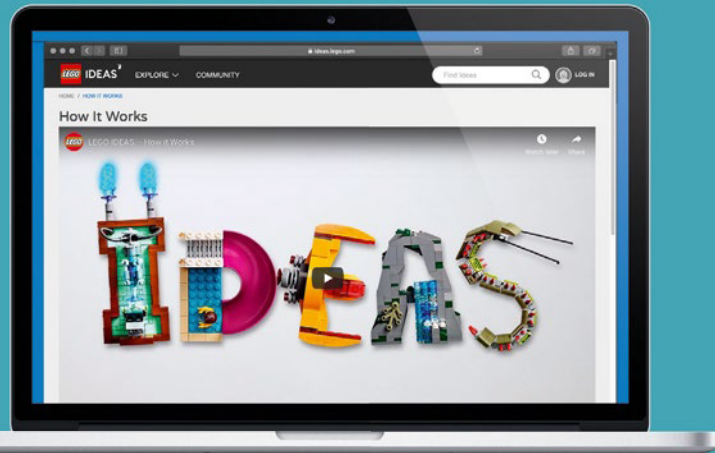

ideas.LEGO.com



LEGO® REVIEW  
LEGO® PRÜFUNG  
EXAMEN PAR LEGO®  
REVIEW LEGO®  
REVISIÓN DE LEGO®  
AVALIAÇÃO LEGO®  
LEGO® VÉLEMÉNYEZÉS  
LEGO® RECENZIJA  
乐高®评论

NEW LEGO® PRODUCT  
NEUES LEGO® PRODUKT  
NOUVEAU PRODUIT LEGO®  
NUOVO PRODOTTO LEGO®  
NUEVO PRODUCTO LEGO®  
NOVO PRODUTO LEGO®  
ÚJ LEGO® TERMÉK  
JAUNS LEGO® PRODUKTS  
新的乐高®产品



Sesame Street® and associated characters, trademarks and design elements are owned and licensed by Sesame Workshop.  
© 2020 Sesame Workshop. All rights reserved.

©Disney. Based on the "Winnie the Pooh" works by A.A. Milne and E.H. Shepard.



2x  
407001



8x  
654101



7x  
300501



2x  
6242241



1x  
9327



2x  
370001



2x  
6285777



1x  
300401



1x  
6153776



6x  
446001



2x  
4121932



2x  
6137926



1x  
4297083



1x  
6218822



1x  
302201



1x  
6366391



4x  
362201



2x  
362301



1x  
6192807



1x  
6363517



8x  
371001



2x  
301001



4x  
6256922



1x  
6031947



3x  
370901



1x  
4173943



2x  
366601



4x  
300901



1x  
4658973

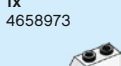

3x  
6223277



2x  
4261693



1x  
4646574

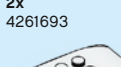

1x  
346001

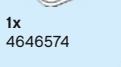

8x  
6282140

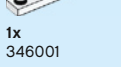

1x  
6366229



2x  
447701

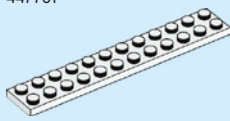

1x  
244501



2x  
6352222



1x  
6261357



2x  
6024495



10x  
6249809



1x  
6283875



1x  
6100203



1x  
6130008



1x  
6332148



6x  
6121485



8x  
6282140



1x  
6366229



2x  
302426



1x  
6134617



1x  
6104209



2x  
6284699



1x  
6279875



6x  
6173119



1x  
6308883



1x  
6271869



4x  
6286381



1x  
6116604



1x  
370726



2x  
6096955



4x  
6186012



3x  
4579659



3x  
4614158



4x  
6186009



2x  
6092602



3x  
4570877



2x  
6069259



1x  
6361813



2x  
6361744



8x  
6362419



28x  
6245250



5x  
6252041



1x  
6211814



1x  
6253231



3x  
6240204



1x  
6251294

5

8

1x  
6093260



1x  
6218359



1x  
6029690

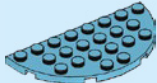

2x  
6138571

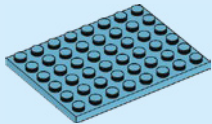

1x  
6097036



1x  
6251591



1x  
6294514



2x  
6294532



2x  
6296003



1x  
6236962



2x  
6327629



1x  
6015449

1x  
6101254



1x  
6092591



1x  
6310835



3x  
4521914



2x  
4528604



10x  
6330148



3x  
6093038



3x  
6047415



2x  
6363523



4x  
6257599

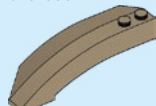

2x  
6361745



2x  
6361746

2x  
6248944



1x  
6092568



4x  
4211166



3x  
6075208



4x  
4211483



4x  
4211398



1x  
4211815



1x  
6347992



3x  
4211805



1x  
4211051



1x  
6269935



1x  
4227398



2x  
4257526

1x  
4162916



1x  
4296785



2x  
6231925



1x  
4490599



5x  
6207933



2x  
4538126



4x  
6284379



2x  
6322139



1x  
6003147



3x  
6252838



2x  
6296657



6x  
6190252



3x  
4523159



1x  
6146054



3x  
6262138



1x  
6323688



Customer Service  
Kundenservice  
Service Consommateurs  
Servicio Al Consumidor  
LEGO.com/service or dial



: 00800 5346 5555  
: 1-800-422-5346

# WIN

GO TO [WWW.LEGO.COM/PRODUCTFEEDBACK](http://WWW.LEGO.COM/PRODUCTFEEDBACK) AND  
GIVE US YOUR SHORT **FEEDBACK** ABOUT THIS  
LEGO® SET FOR A CHANCE TO WIN  
A COOL LEGO PRIZE.

Terms & Conditions apply

## LEGO.com/productfeedback



### GEWINNE

Erzähle uns auf  
[www.LEGO.com/productfeedback](http://www.LEGO.com/productfeedback)

etwas über die Erfahrungen, die du mit  
diesem LEGO® Set gemacht hast, und  
sichere dir die Chance auf einen coolen  
LEGO Preis!

Es gelten die Teilnahmebedingungen

### GAGNE

Rends-toi sur  
[www.LEGO.com/productfeedback](http://www.LEGO.com/productfeedback)

et donne-nous quelques commentaires  
sur ce produit LEGO® pour avoir une  
chance de gagner un prix LEGO !

Voir Conditions Générales

### GANAN

Visita  
[www.LEGO.com/productfeedback](http://www.LEGO.com/productfeedback)

y envíanos tu opinión acerca de este set  
LEGO®. ¡Participarás en el sorteo de un  
premio LEGO!

Términos y Condiciones aplicables

### 获取奖品

登录  
[www.LEGO.com/productfeedback](http://www.LEGO.com/productfeedback)

给出关于此乐高®套装的简短反馈，  
就有机会获得炫酷乐高奖品

《条款及条件》适用